

**1 FULL-WIDTH 1st PLANK**  
SCALE: 3"=1'-0" REF:

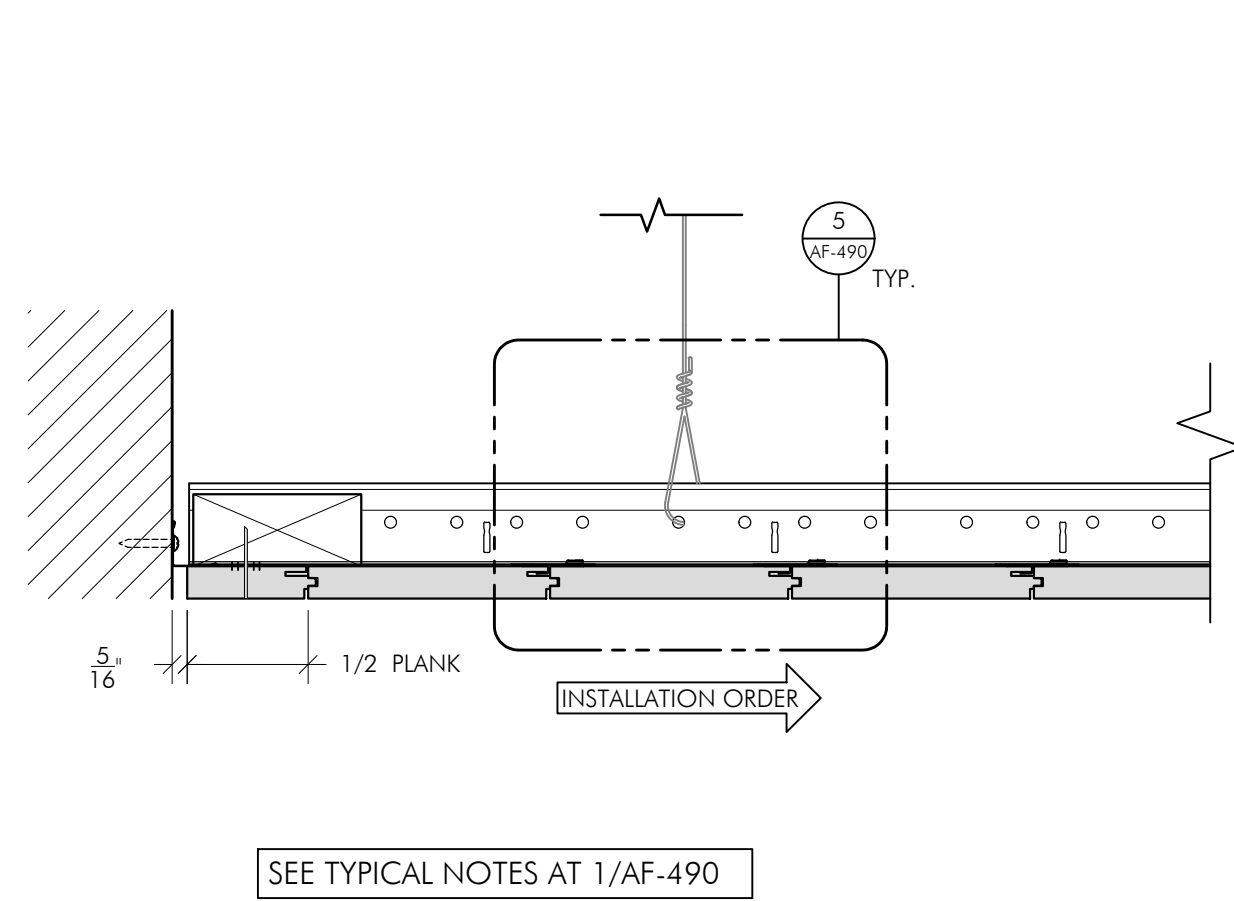

**2 1/2 WIDTH STARTING PLANK**  
SCALE: 3"=1'-0" REF:

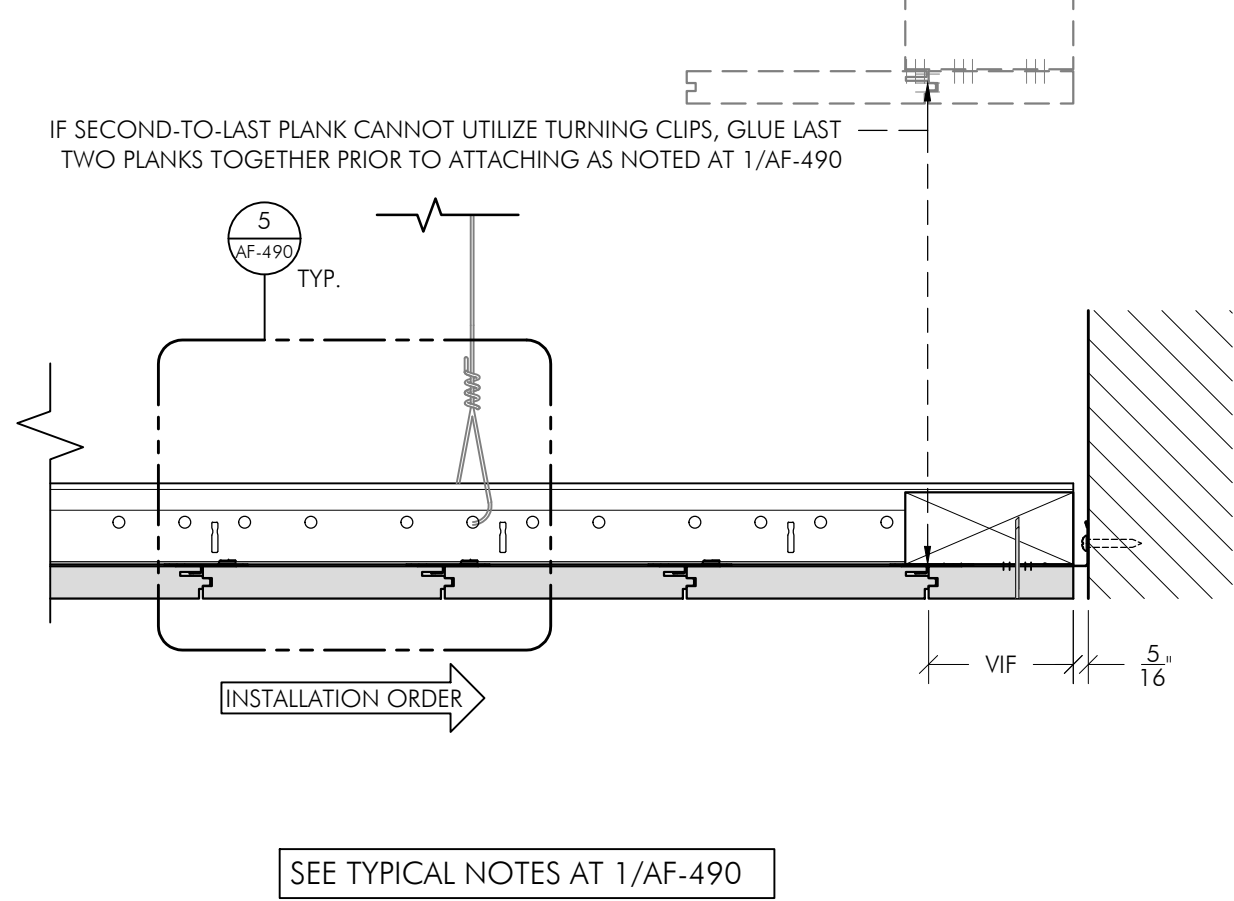

**3 LAST PLANK**  
SCALE: 3"=1'-0" REF:

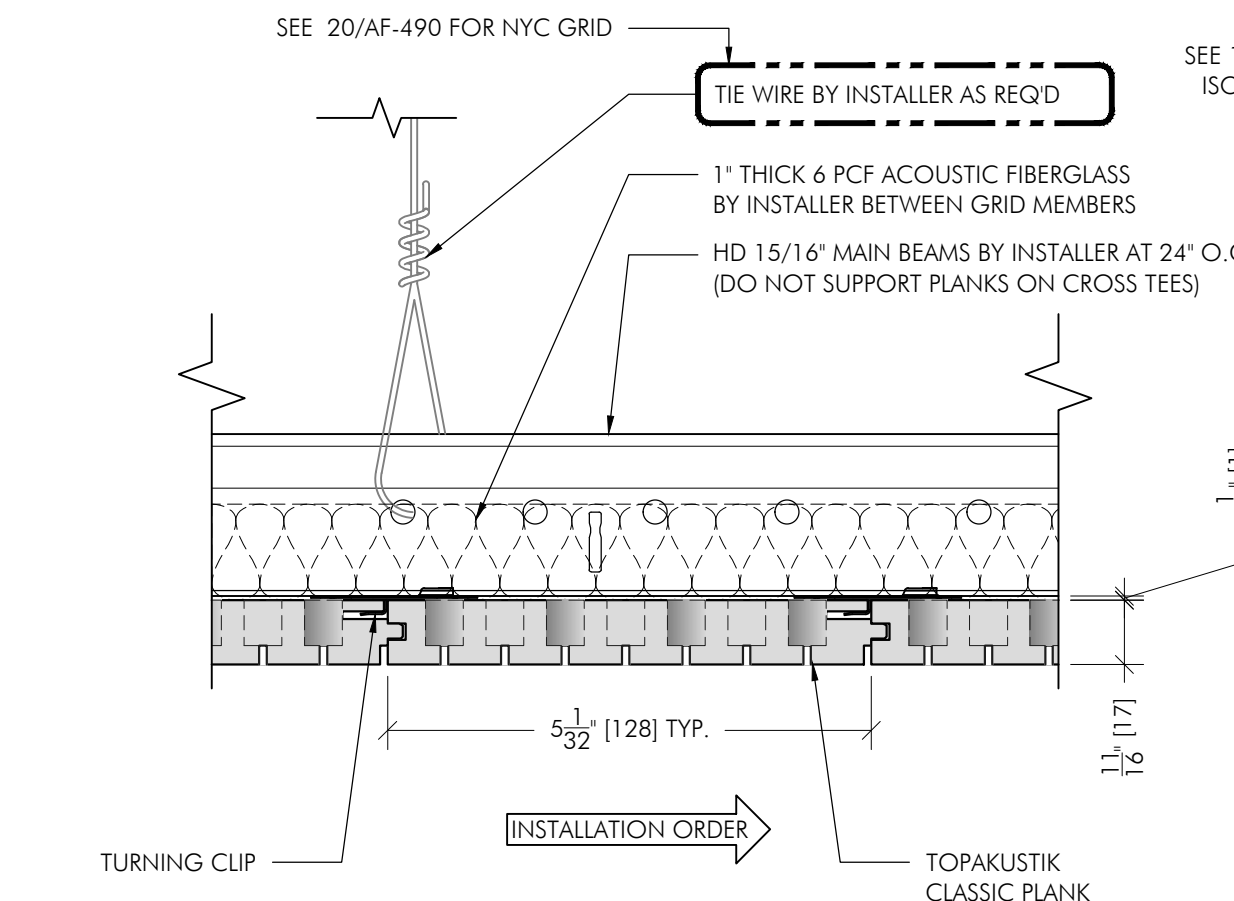

**5 TRANSVERSE DETAIL**  
SCALE: 6"=1'-0" TYPICAL

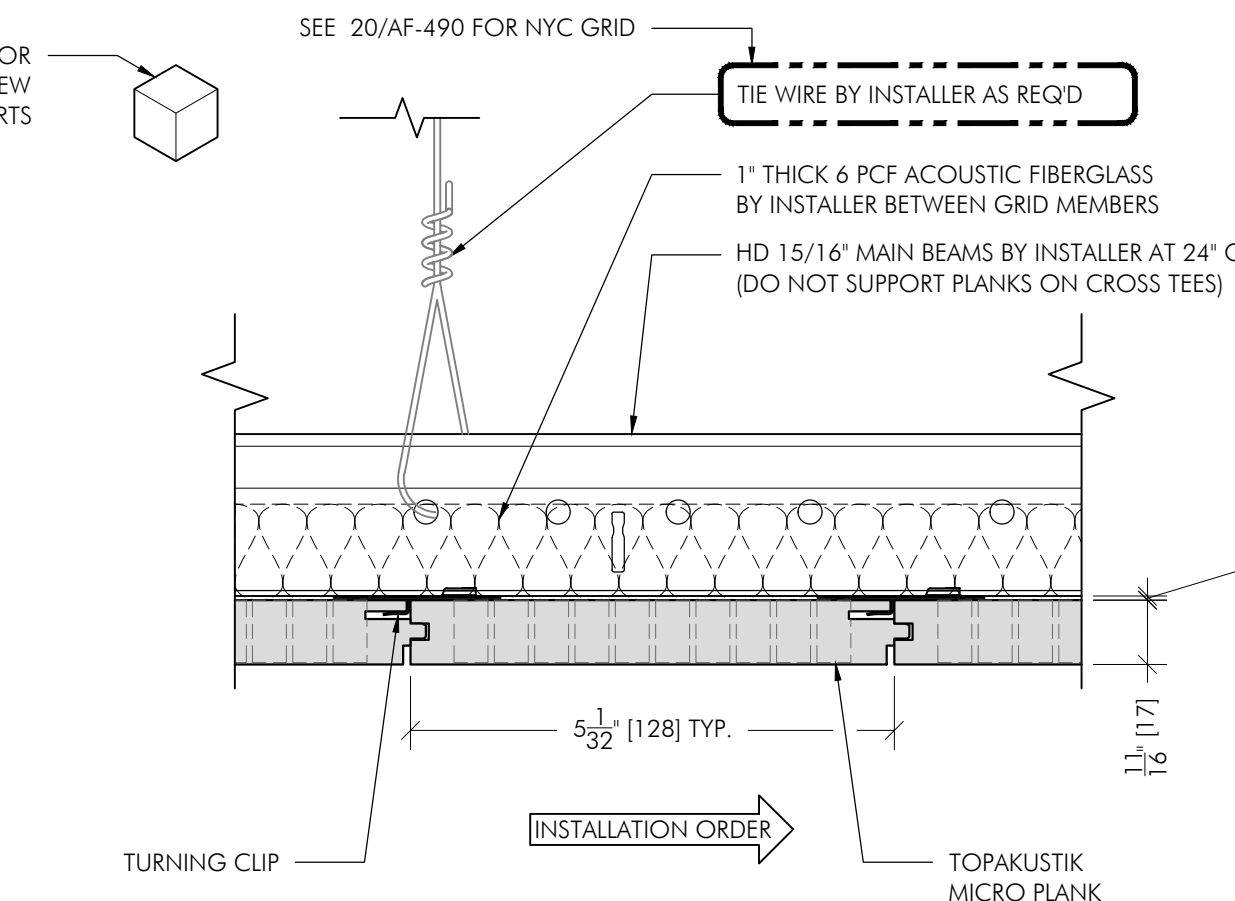

**5 TRANSVERSE DETAIL**  
SCALE: 6"=1'-0" TYPICAL

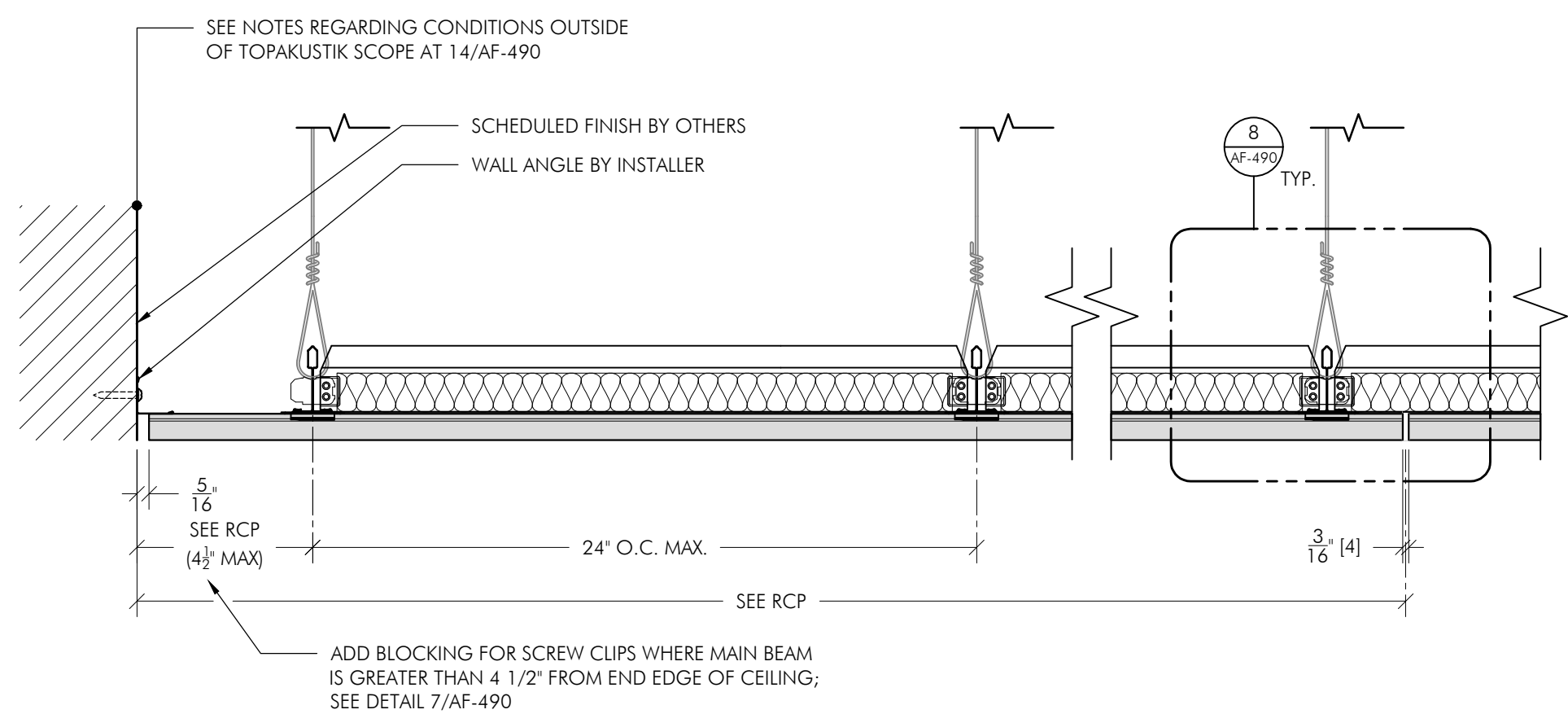

**6 CEILING SECTION - LONGITUDINAL (TYPICAL)**  
SCALE: 3"=1'-0" REF:

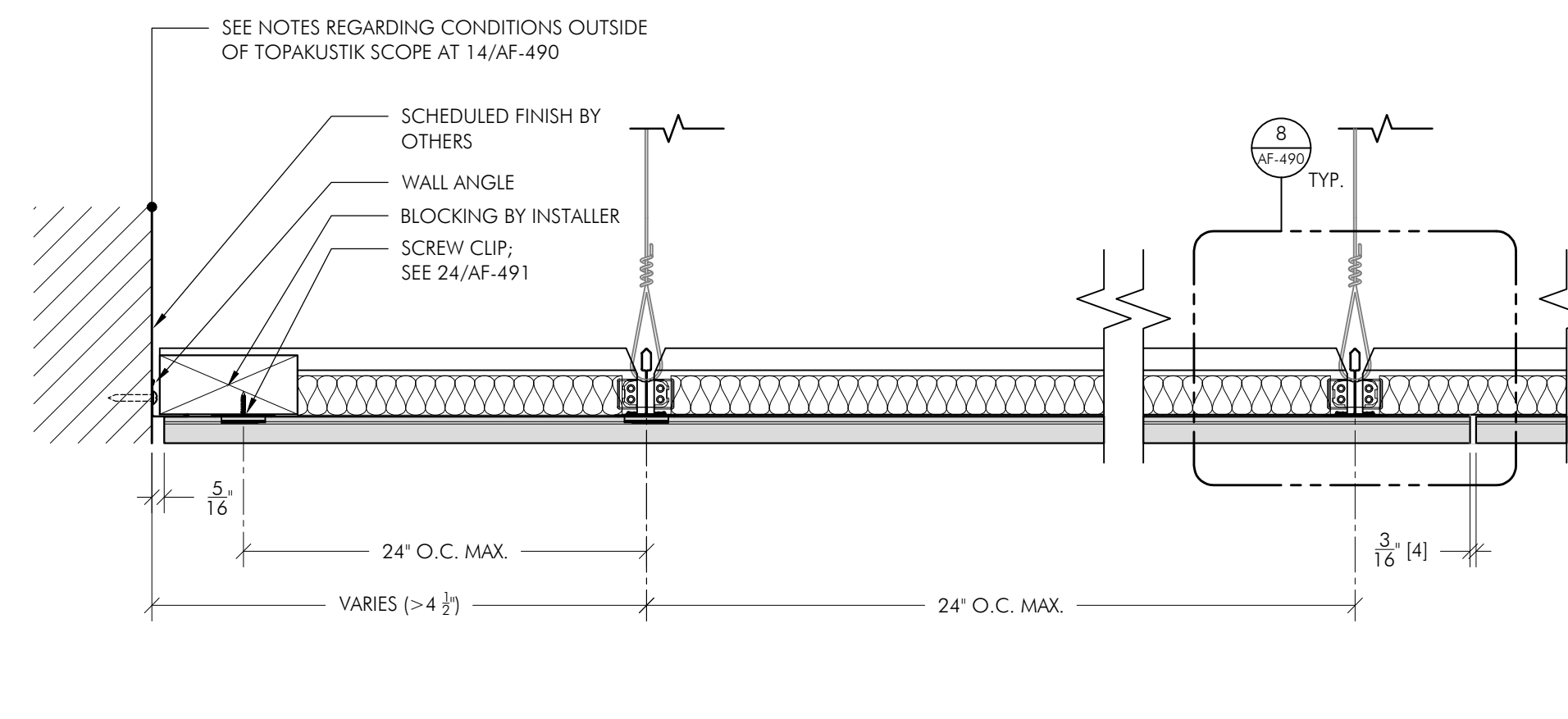

**7 SCREW CLIPS AT EDGE**  
SCALE: 3"=1'-0" REF:

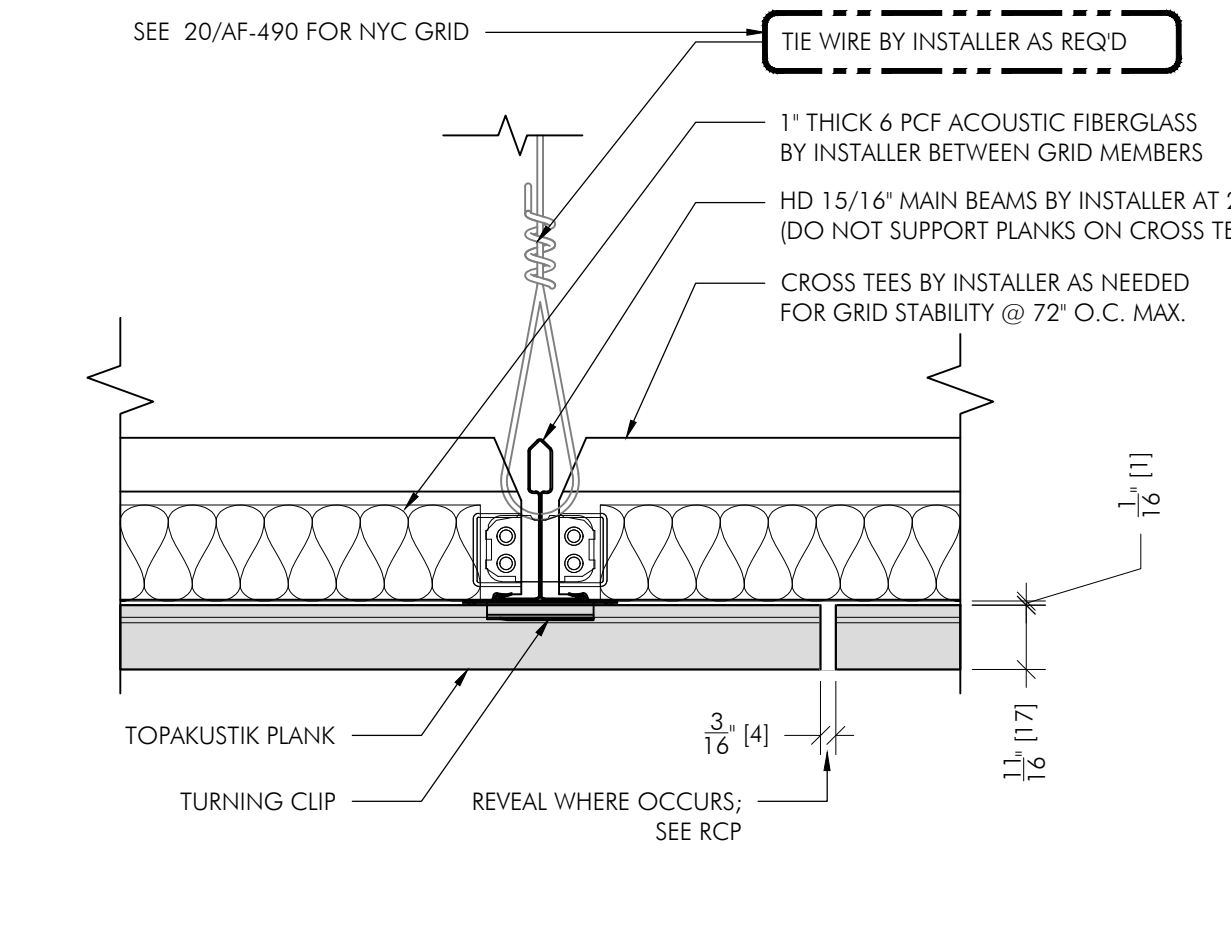

**8 LONGITUDINAL DETAIL**  
SCALE: 6"=1'-0" TYPICAL

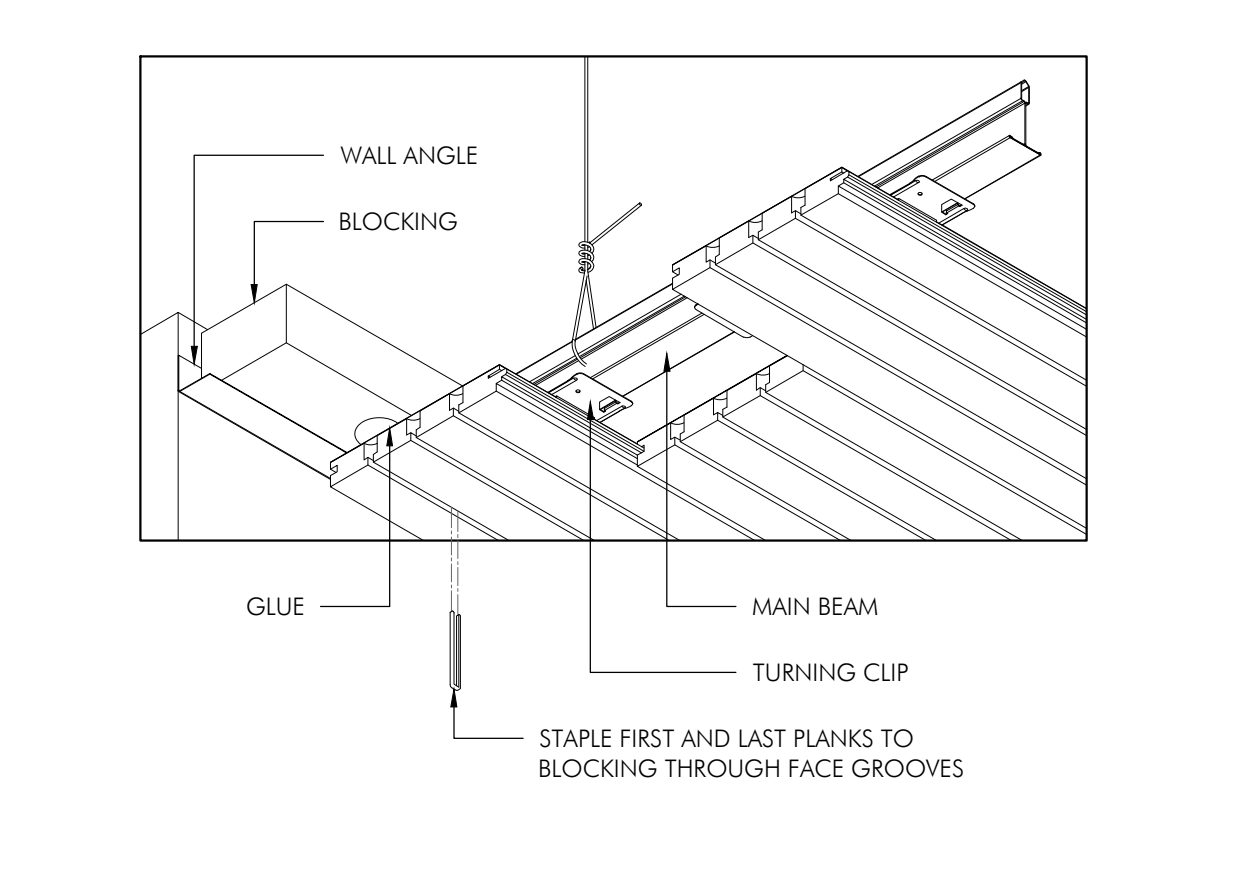

**9 STAPLE FIXATION**  
SCALE: 3"=1'-0" REF:

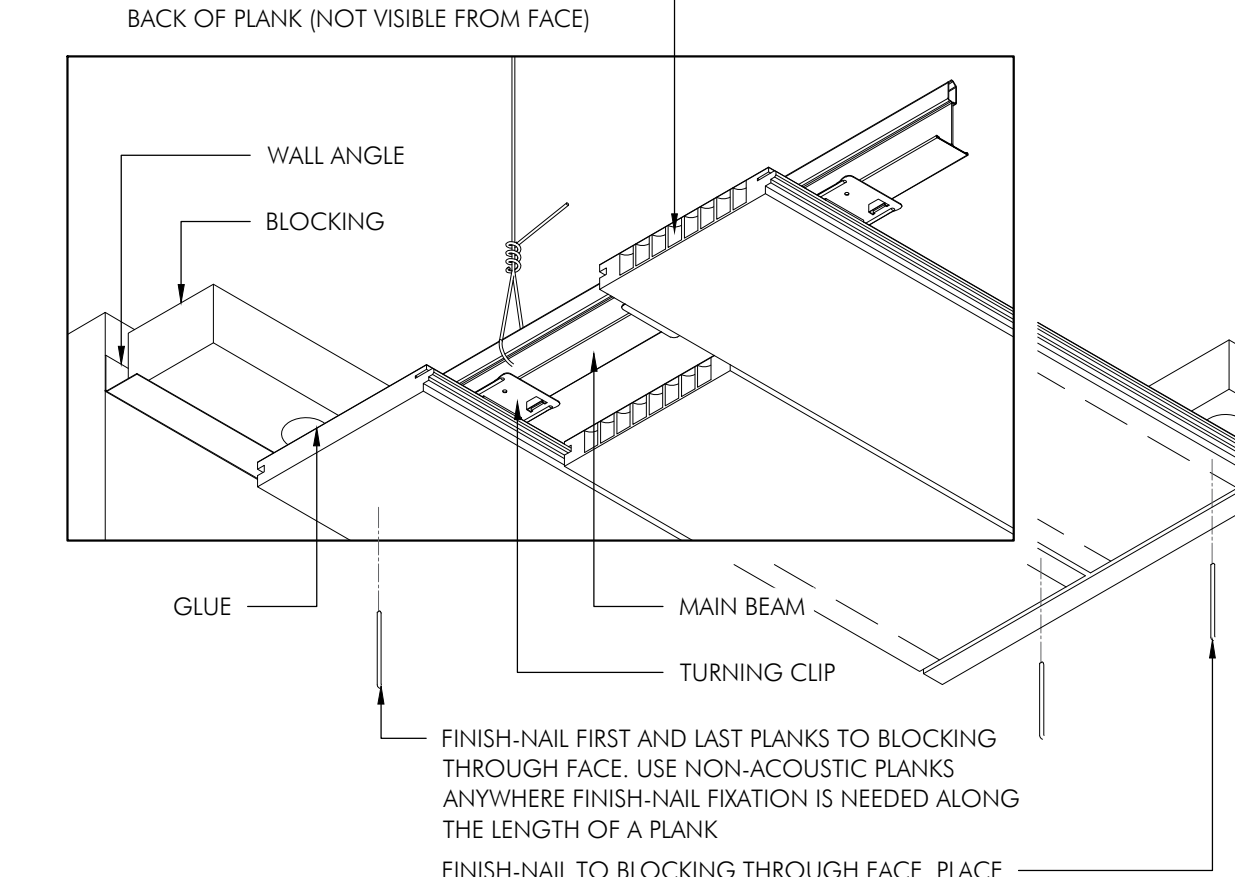

**9 FINISH-NAIL FIXATION**  
SCALE: 3"=1'-0" REF: 1/AF-490

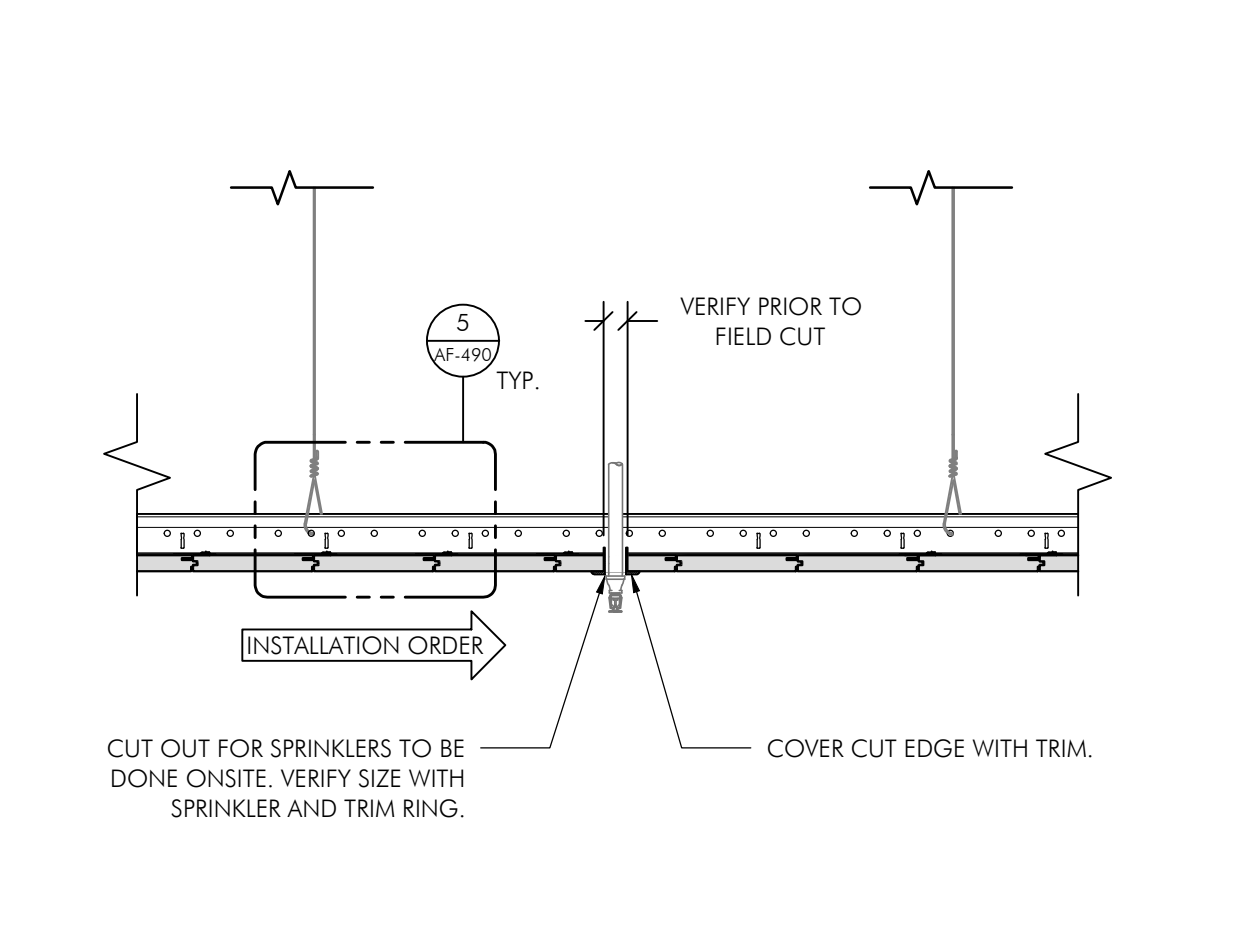

**10 SPRINKLER**  
SCALE: 1 1/2"=1'-0" REF:

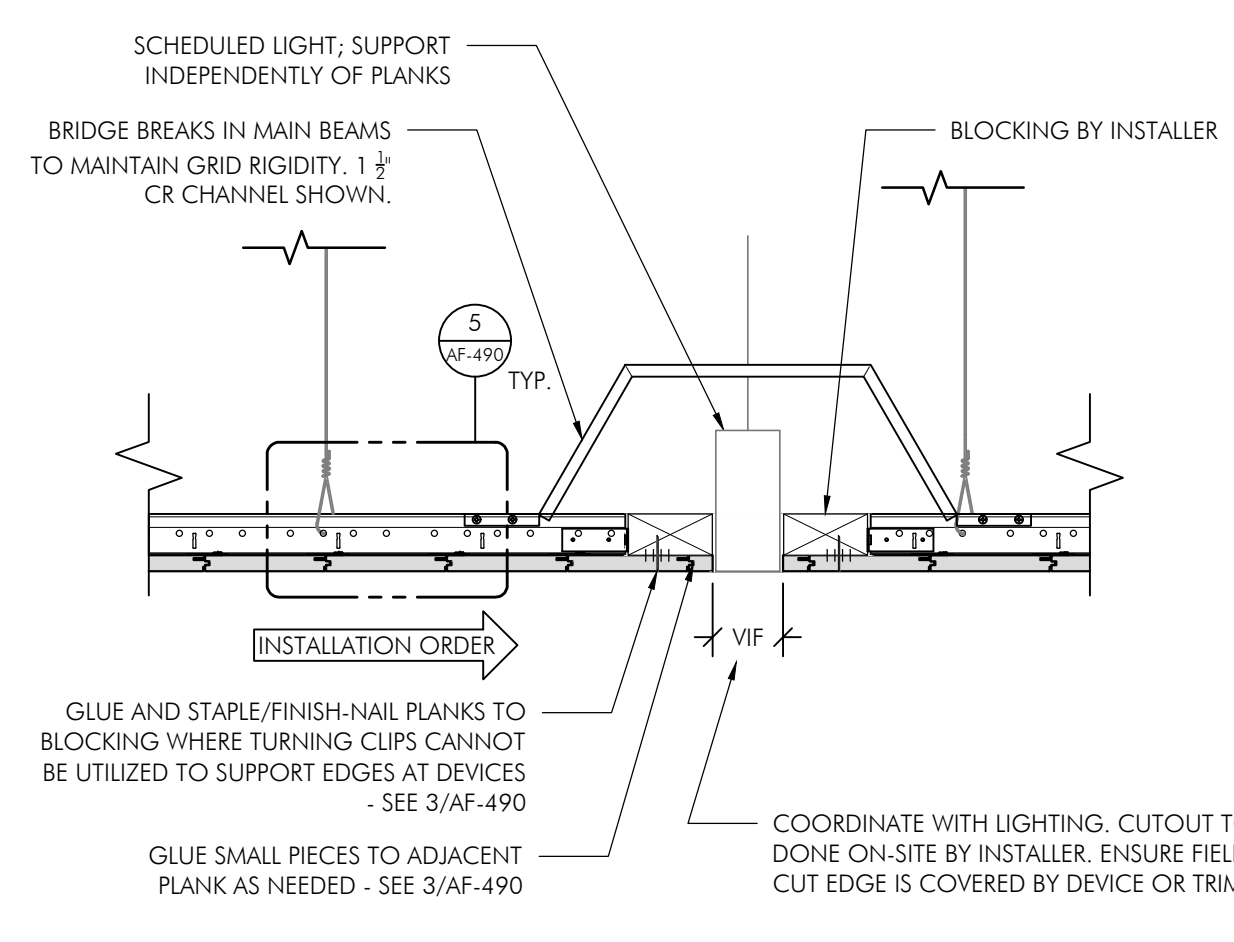

**11 LINEAR LIGHT FIXTURE**  
SCALE: 1 1/2"=1'-0" REF:

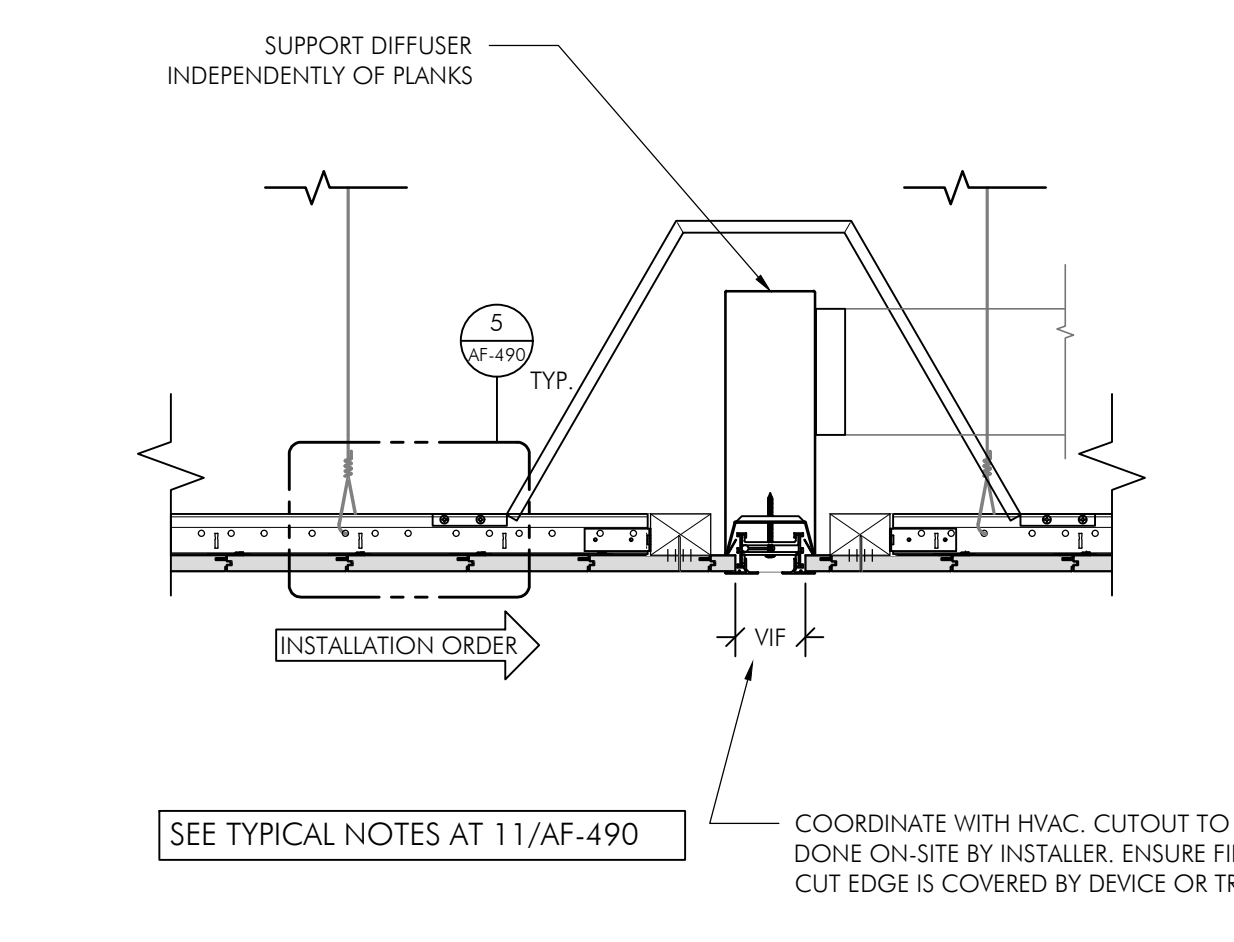

**12 TRANSVERSE SECTION AT DIFFUSER**  
SCALE: 1 1/2"=1'-0" REF:

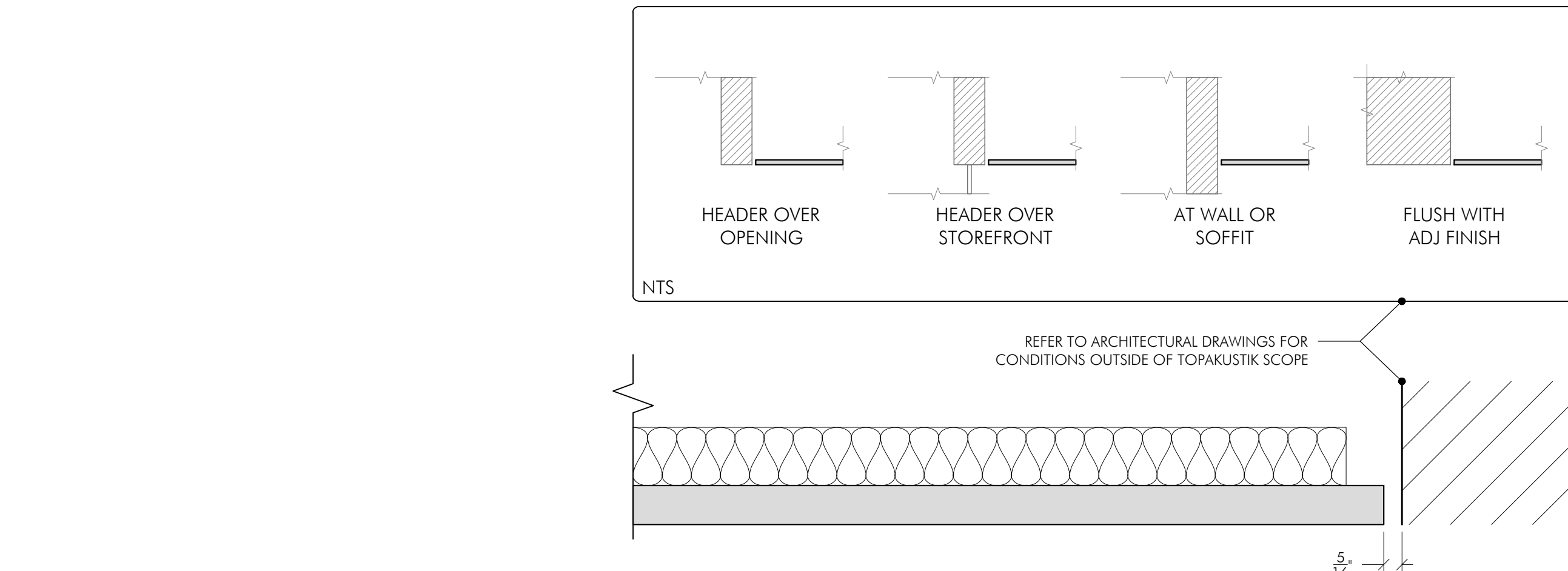

**14 PERIMETER CONDITIONS**  
SCALE: 6"=1'-0" REF: TYPICAL

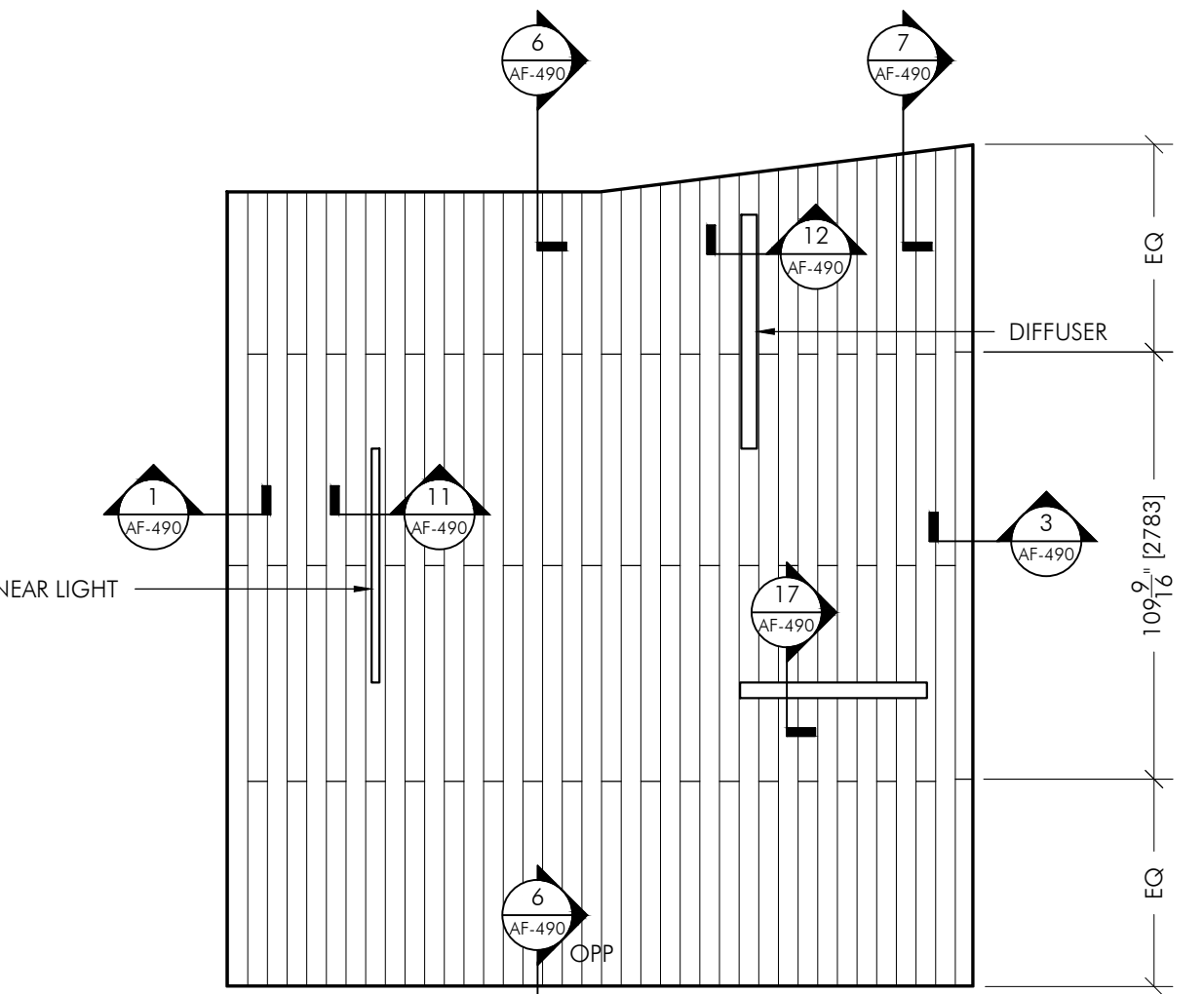

**15 EXAMPLE RCP**  
SCALE: 1/4"=1'-0" REF:

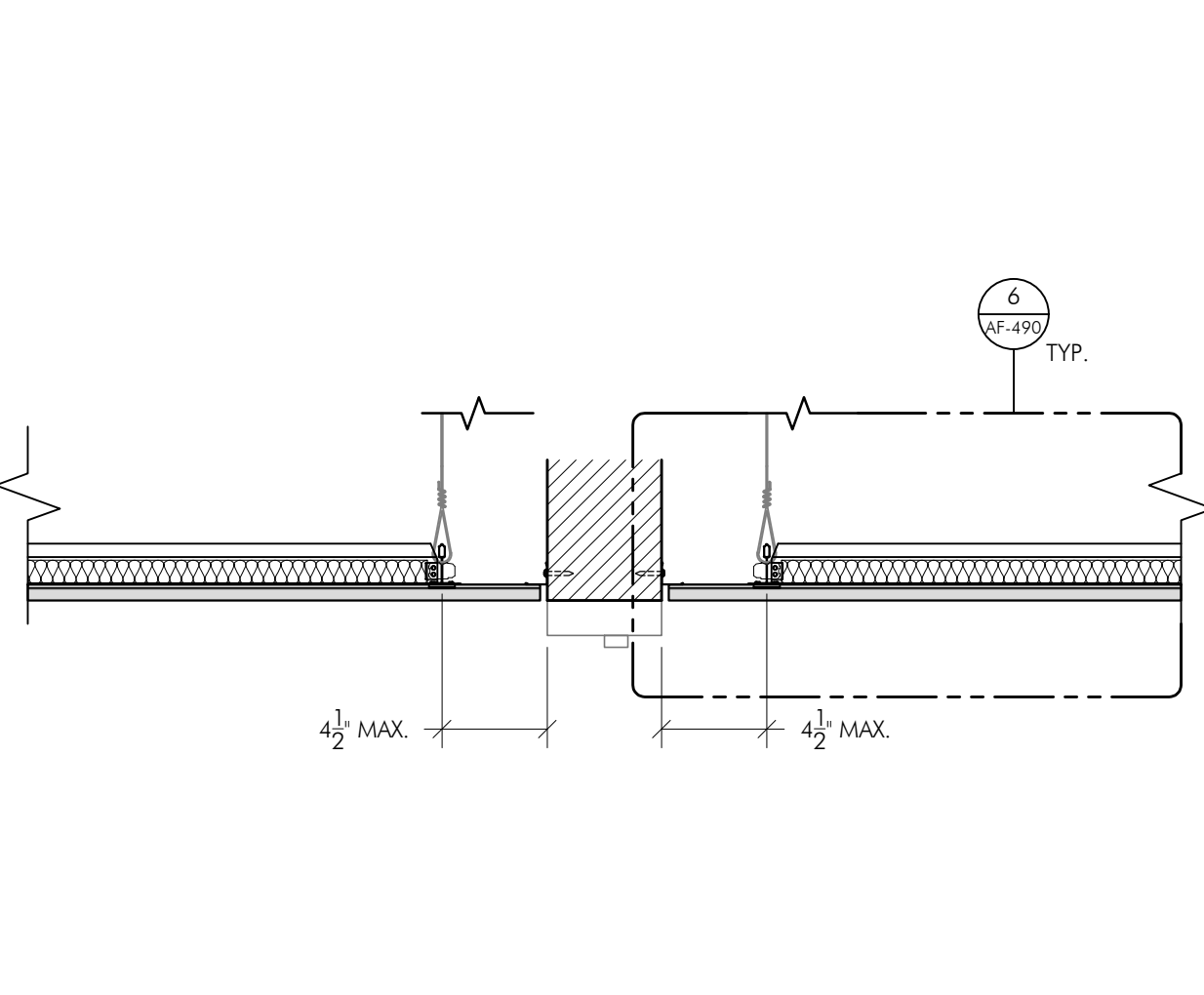

**16 PARTITION HEAD**  
SCALE: 1 1/2"=1'-0" REF:

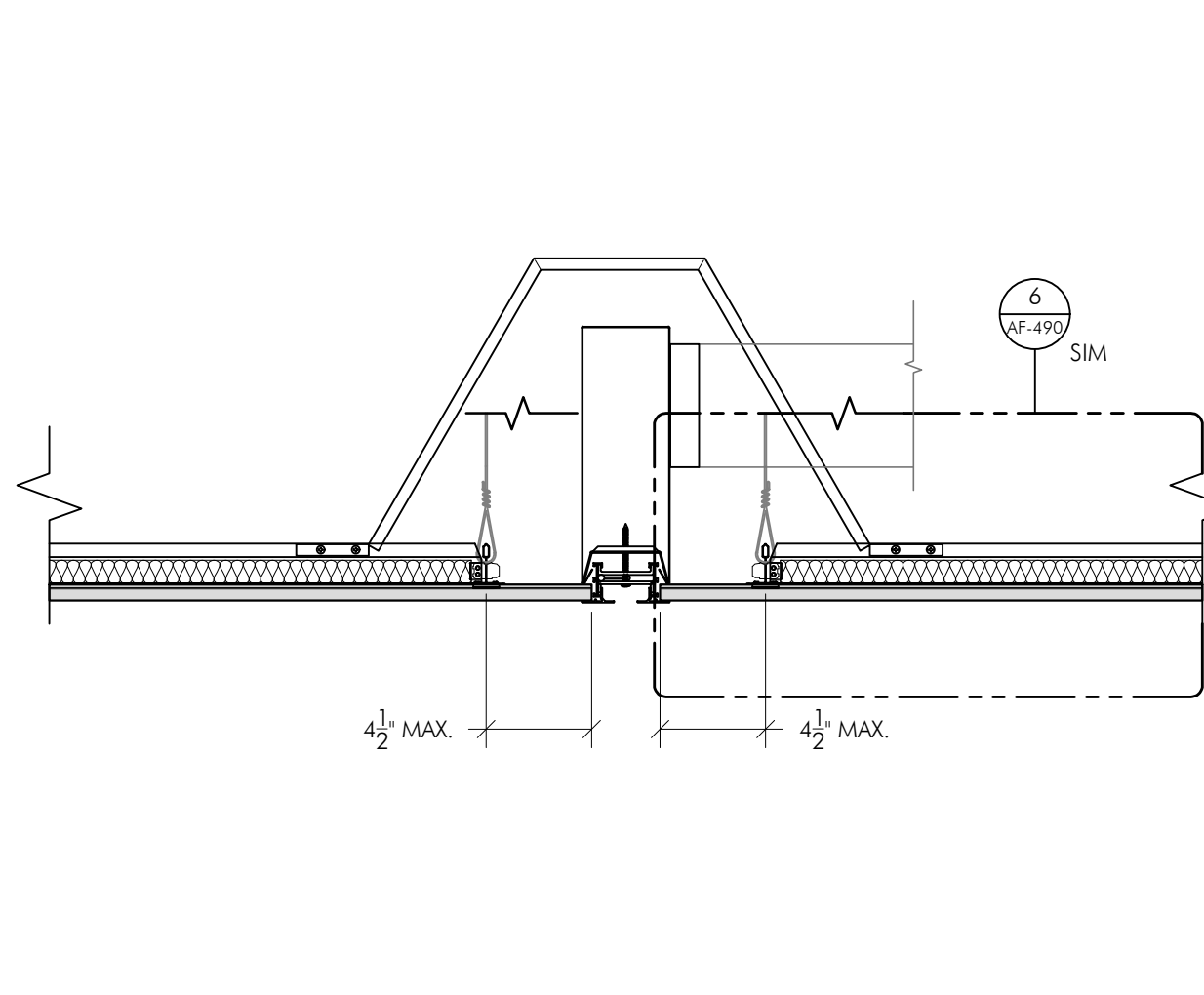

**17 LNGT. SECTION AT DIFFUSER**  
SCALE: 1 1/2"=1'-0" REF:

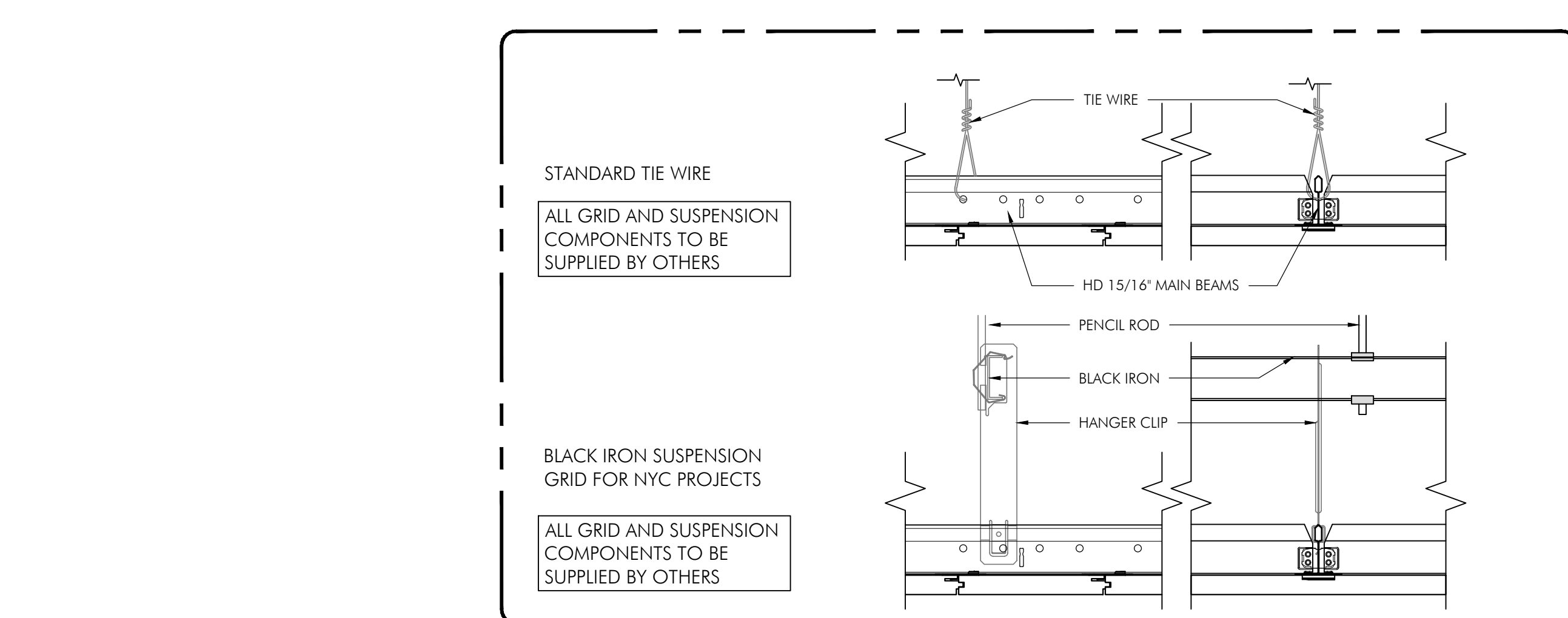

**20 BLACKIRON GRID FOR NYC**  
SCALE: 3"=1'-0" REF: 5 & 8/AF-490

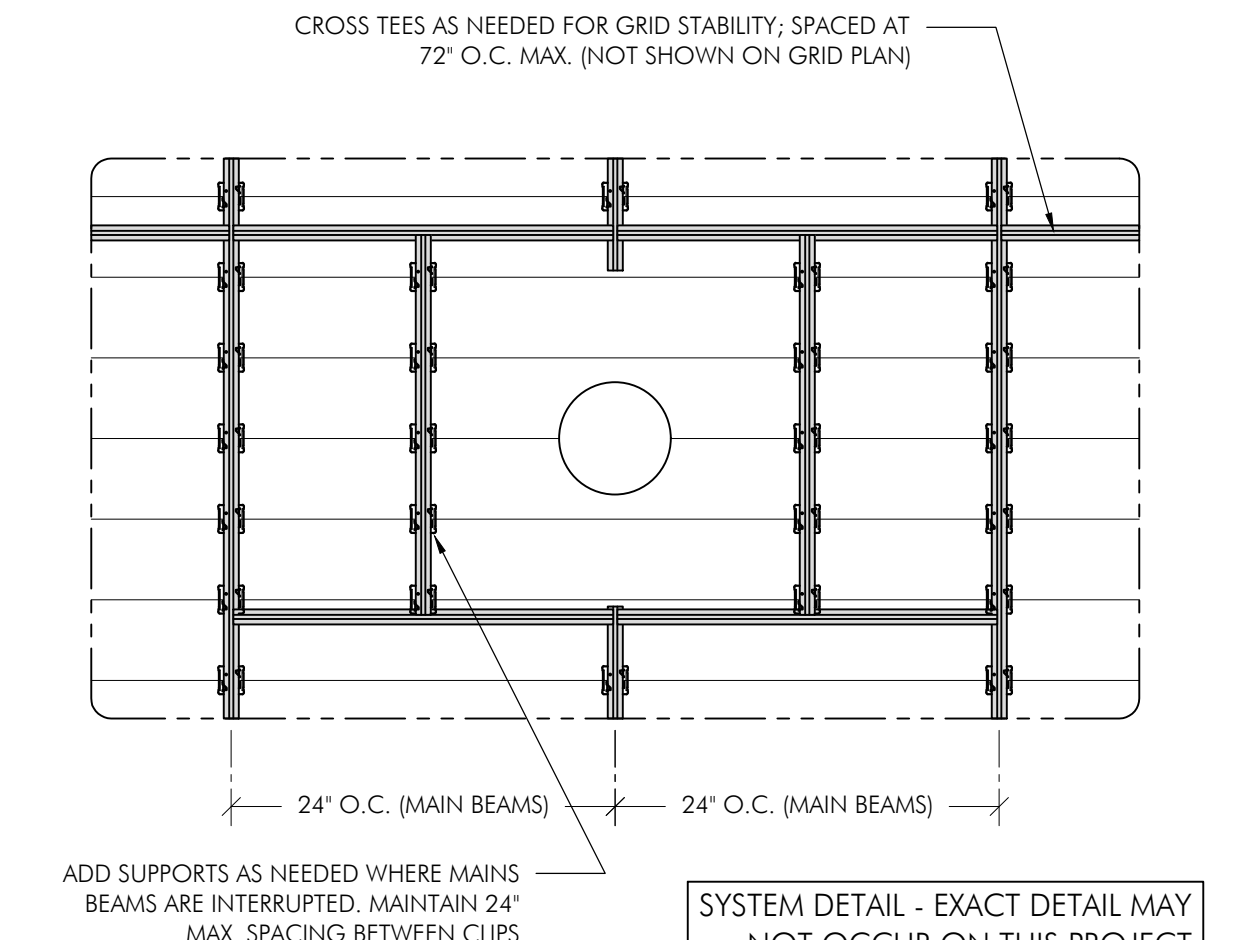

**21 GRID PLAN DETAIL AT DEVICE**  
SCALE: 1"=1'-0" REF:

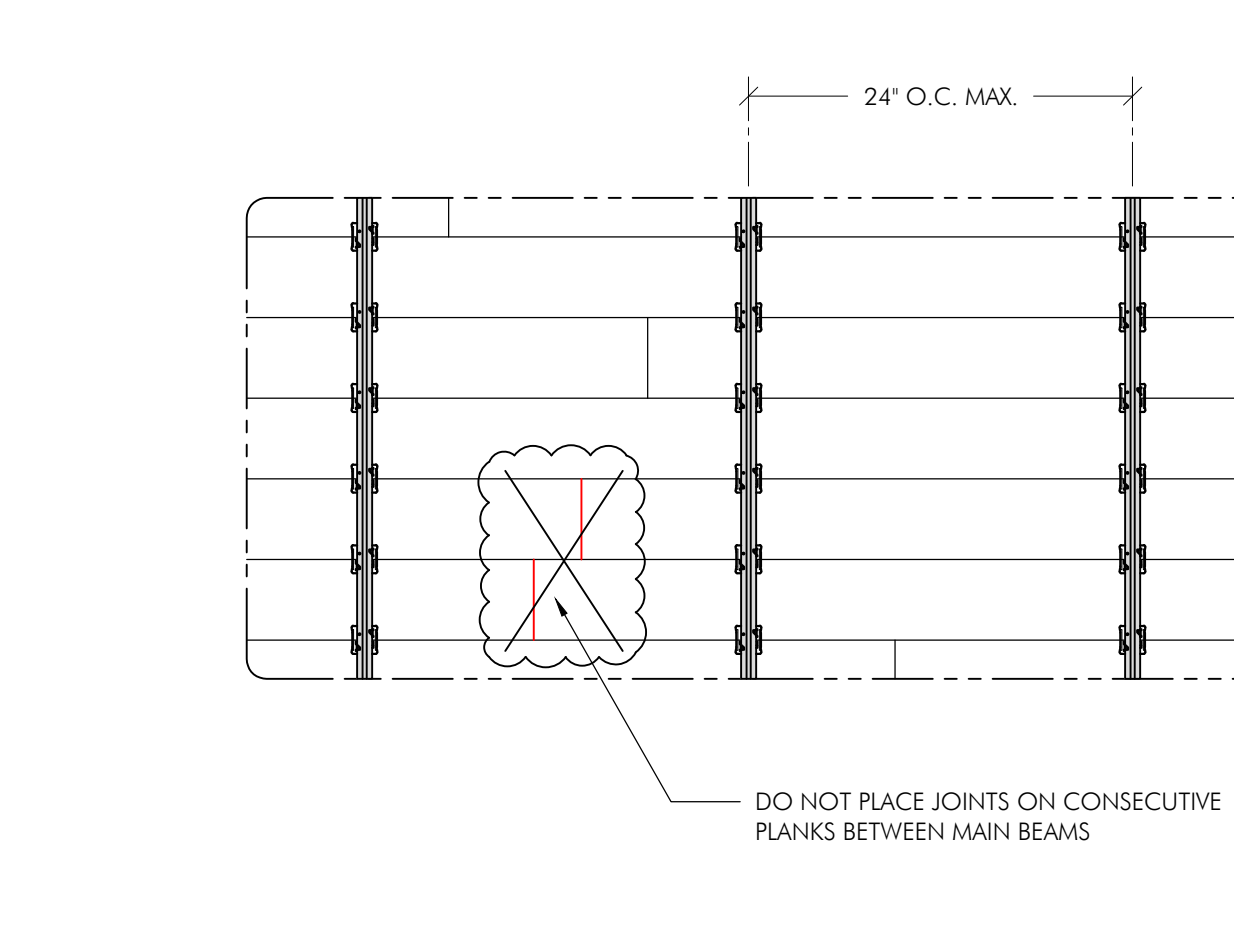

**22 GRID DETAIL RANDOM JOINTS**  
SCALE: 1"=1'-0" REF:

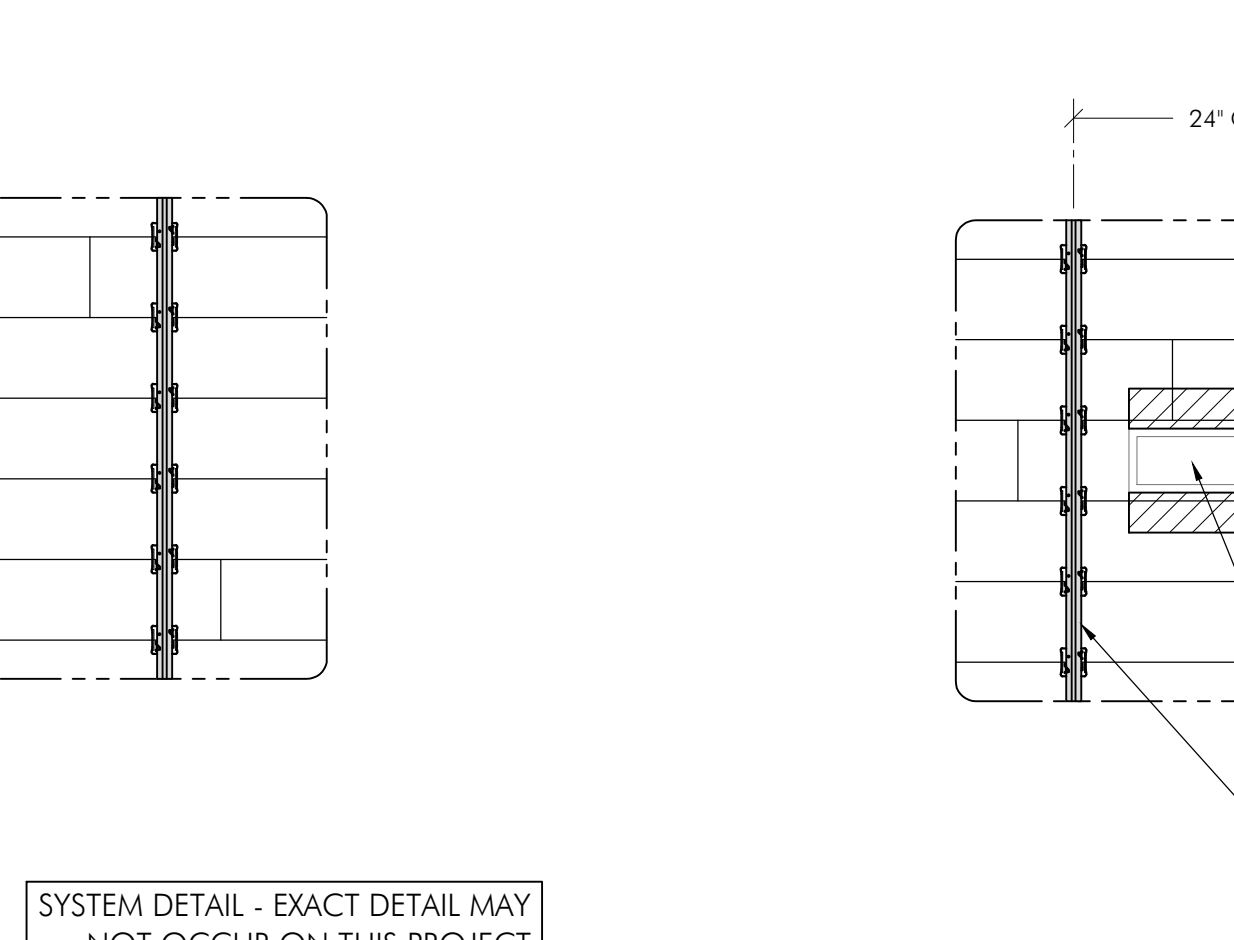

**23 GRID AT LINEAR FIXTURE ALIGNED WITH PLANK**  
SCALE: 1"=1'-0" REF:

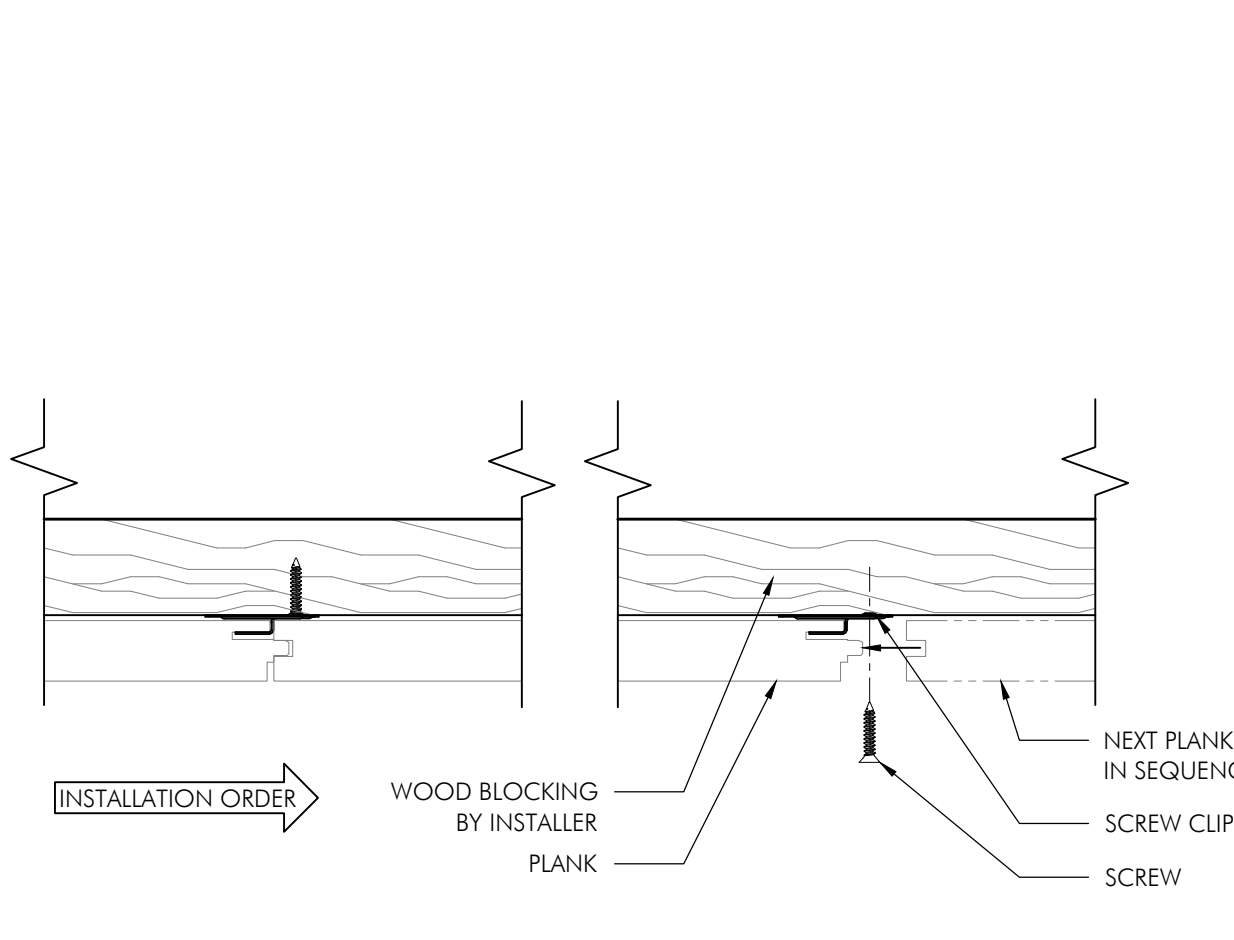

**24 SCREW CLIP FIXATION**  
SCALE: 6"=1'-0" TYPICAL

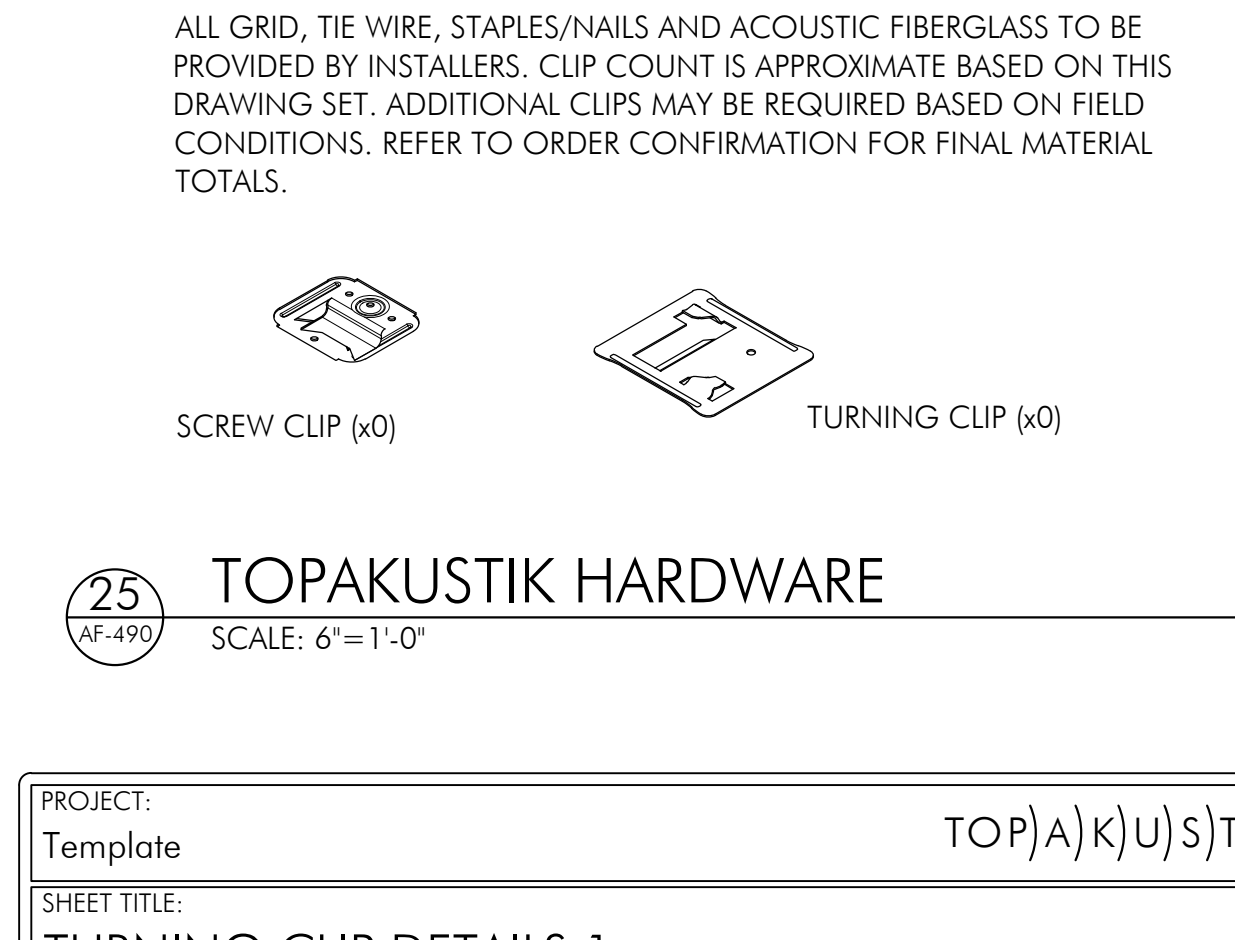

**25 TOPAKUSTIK HARDWARE**  
SCALE: 6"=1'-0" REF:

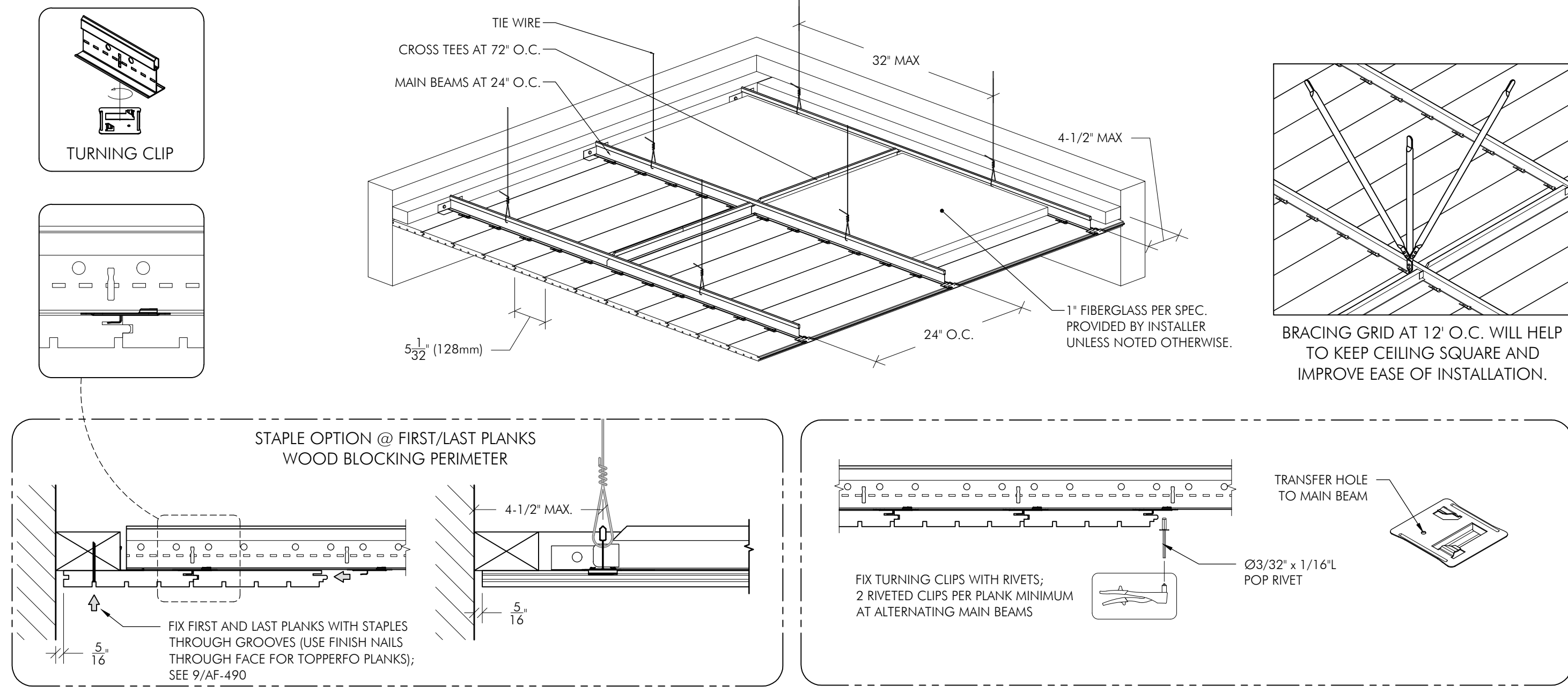

1 TYPICAL TURNING CLIP DETAILS

SCALE: 3"=1'-0"

REF: TYPICAL

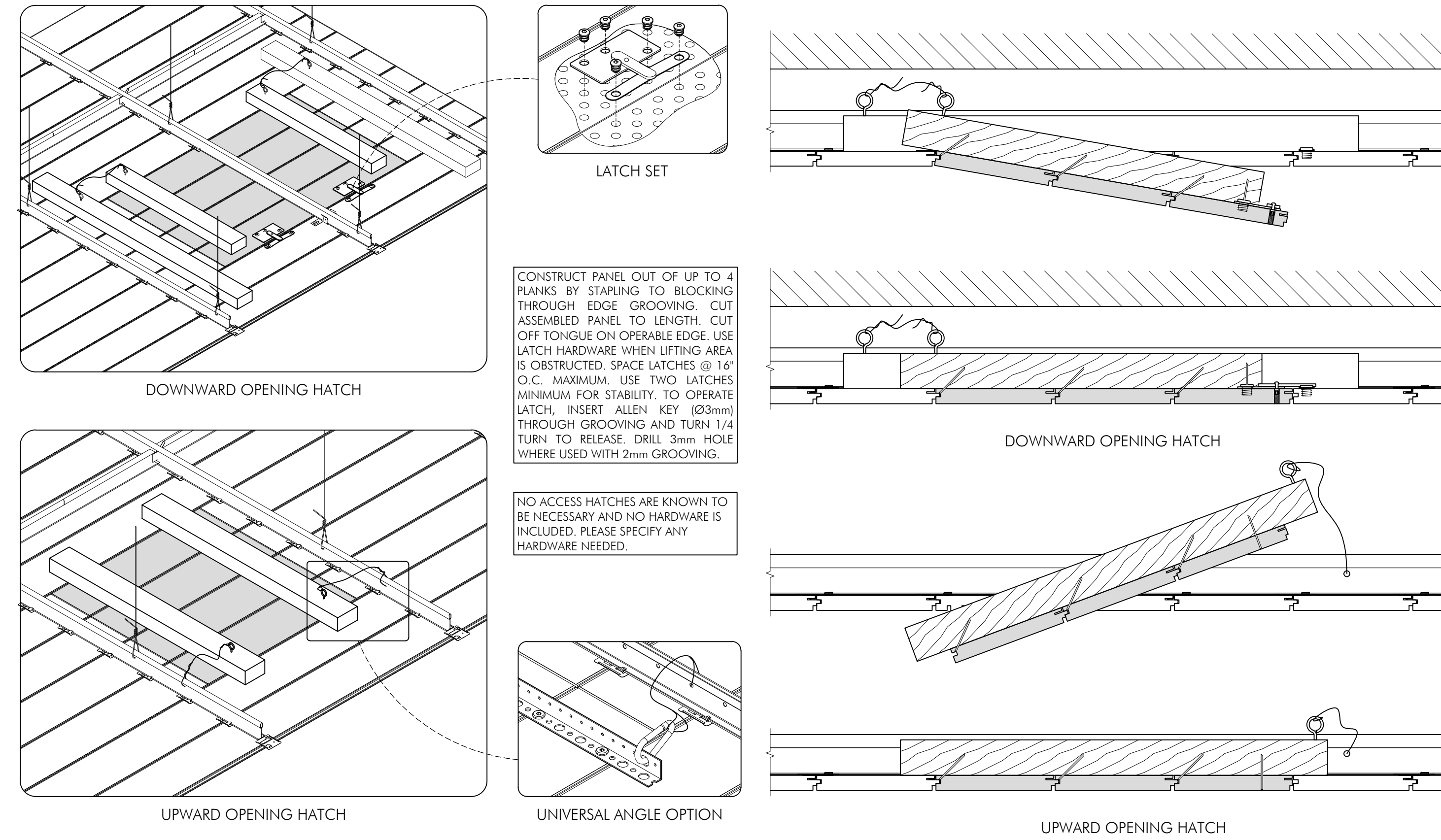

2 TYPICAL 128mm PLANK ACCESS HATCH

SCALE: 3"=1'-0"

REF: TYPICAL

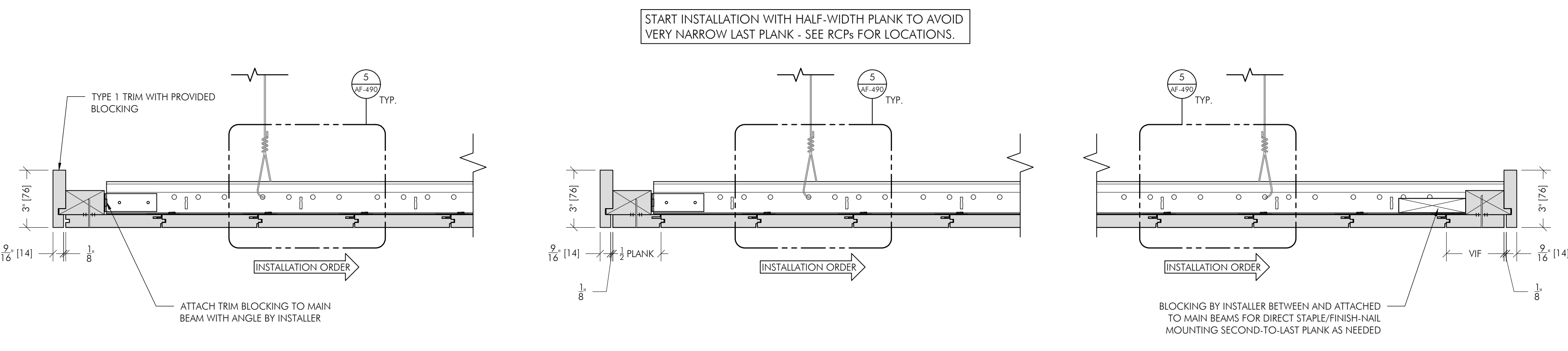

3 FULL-WIDTH 1st PLANK WITH TRIM

SCALE: 3"=1'-0"

REF:

SEE TYPICAL NOTES AT 1/AF-490

4 1/2 WIDTH STARTING PLANK

SCALE: 3"=1'-0"

REF:

SEE TYPICAL NOTES AT 1/AF-490

5 TRIM AT LAST PLANK

SCALE: 3"=1'-0"

REF:

SEE TYPICAL NOTES AT 1/AF-490

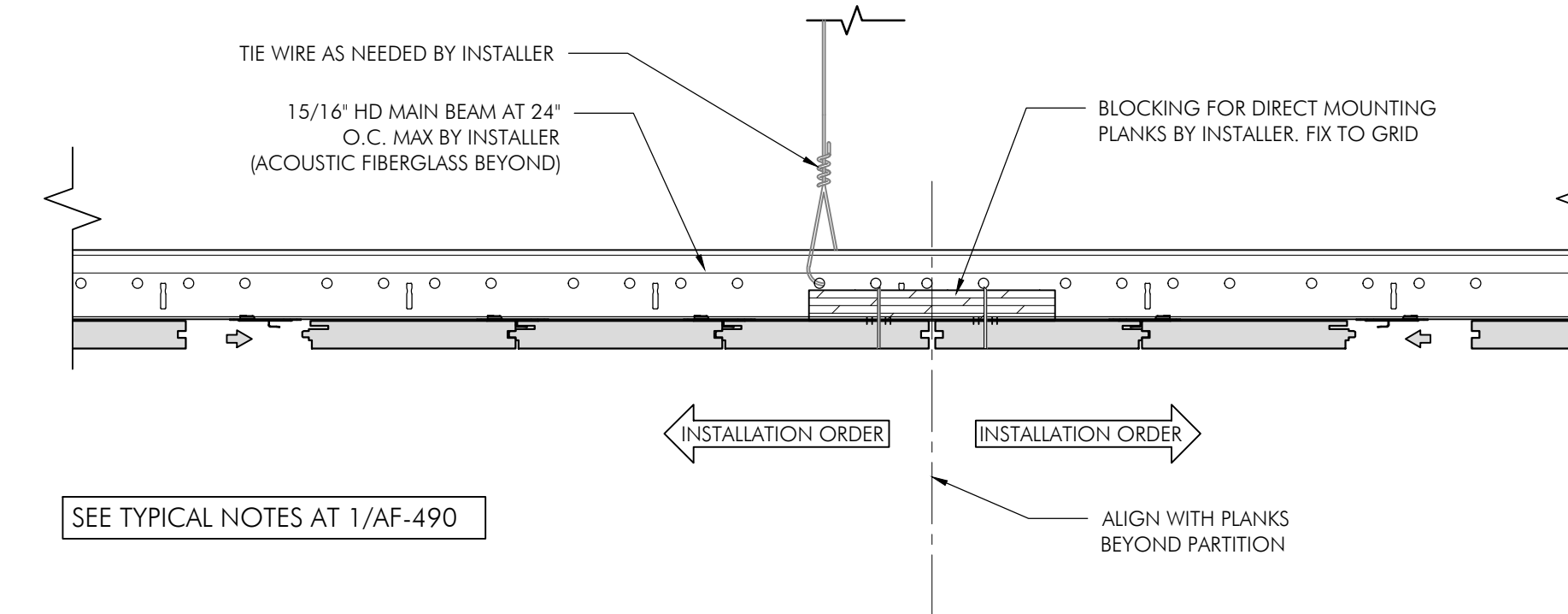

6 ALIGNMENT DETAIL

SCALE: 3"=1'-0"

REF:

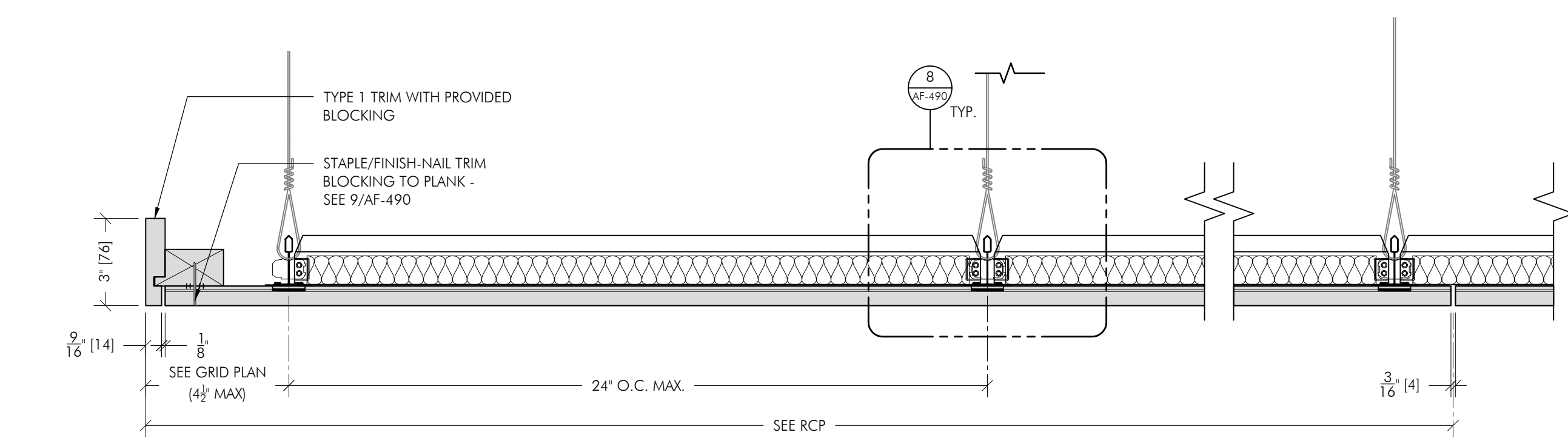

8 CEILING SECTION - LONGITUDINAL AT TYPE 1 TRIM

SCALE: 3"=1'-0"

REF:

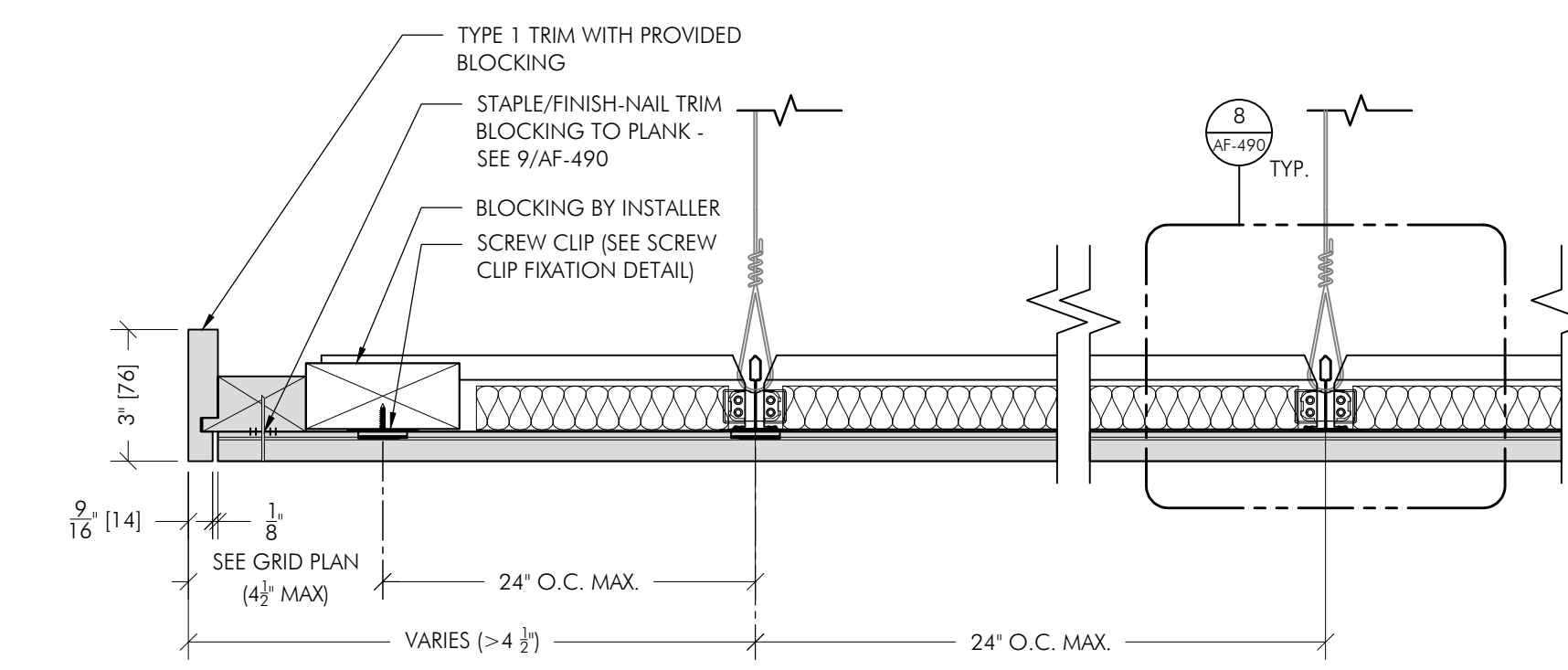

9 CLIPS AT TYPE 1 TRIM

SCALE: 3"=1'-0"

REF:

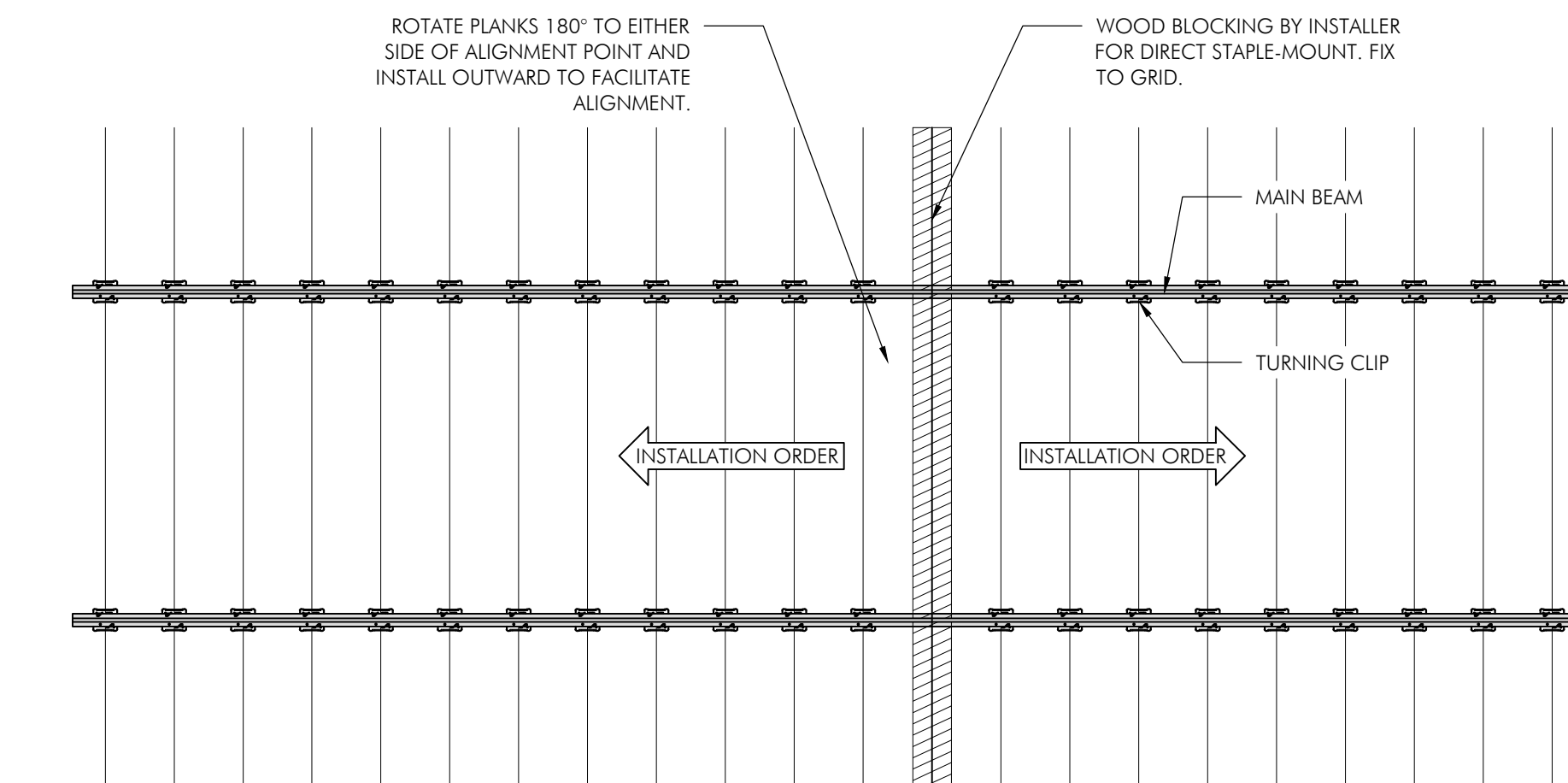

10 GRID DETAIL AT ALIGNED STARTING POINT

SCALE: 1"=1'-0"

REF:

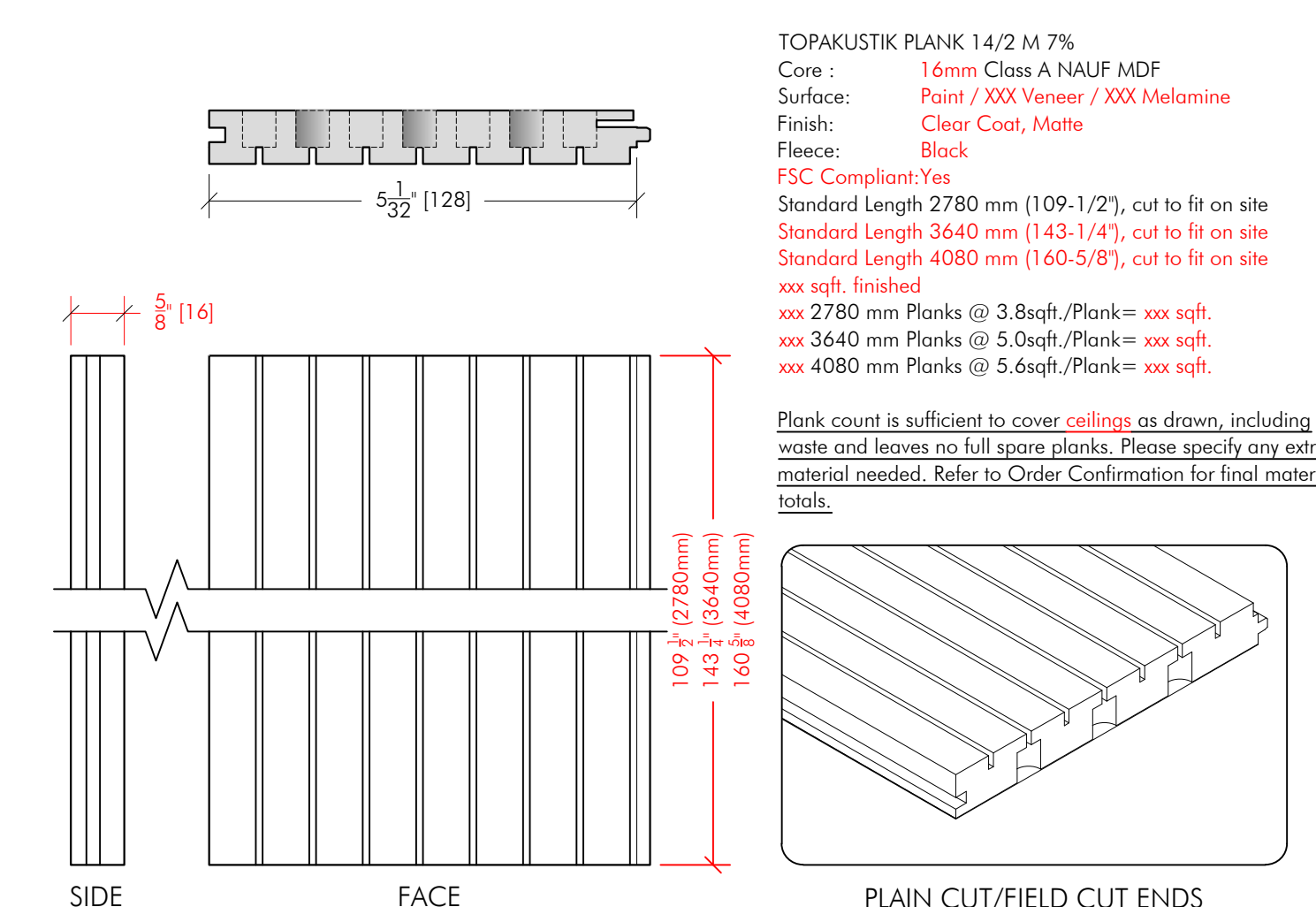

12 14/2 TOPAKUSTIK PLANK

SCALE: 6"=1'-0"

PROJECT:	Template			TOPAKUSTIK
SHEET TITLE:	TURNING CLIP DETAILS 2			
REVISIONS:	ISSUE DATE:	SCALE:	NOTED	3 <sup>rd</sup> ANG.
▲	1/4/2024			
▲	PROJ MGR:	DRAWN BY:	PAGE NO:	REV NO:
▲			17/29	0
▲	PRODUCTION TOLERANCE:	AF-491		
▲	0.36 ± 1/32"			
▲	± 1/32" PER 36" OF PRODUCT			