

EDGE BANDED
WITH GROOVES RUNNING
OFF PANEL ENDS

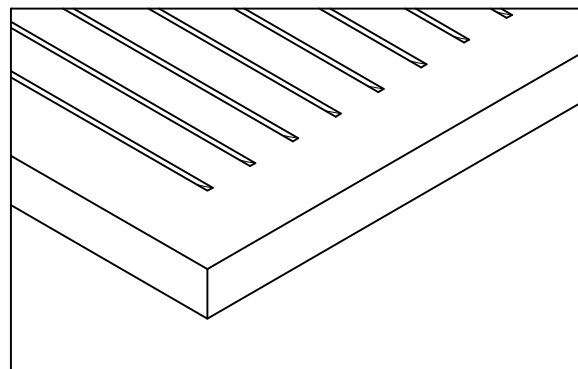

EDGE BANDED
WITH GROOVES HELD BACK
FROM PANEL ENDS

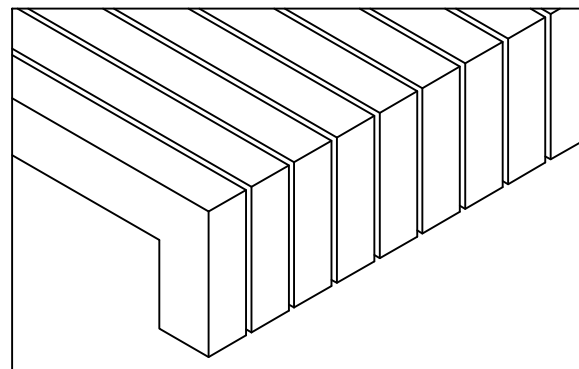

MITERED RETURN
FACTORY ATTACHED UP TO 6"

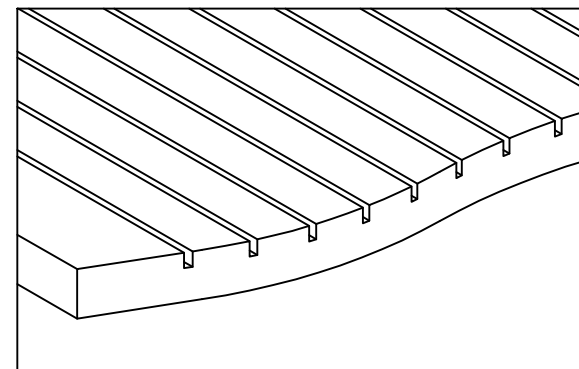

CUSTOM SHAPES

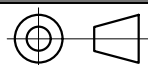
PRODUCT: TOPAKUSTIK PANELS		TOPAKUSTIK 	
SHEET TITLE: PERIMETER OPTIONS		PRODUCTION TOLERANCE: 0" - 36" ±1/32", ±1/32" PER 36" OF PRODUCT	
SCALE: NTS	PAGE NO: 1/3	3 rd ANG. PROJ. 	DRAWN BY: WRM
			REV NO: 0 REV DATE: 04/07/2015

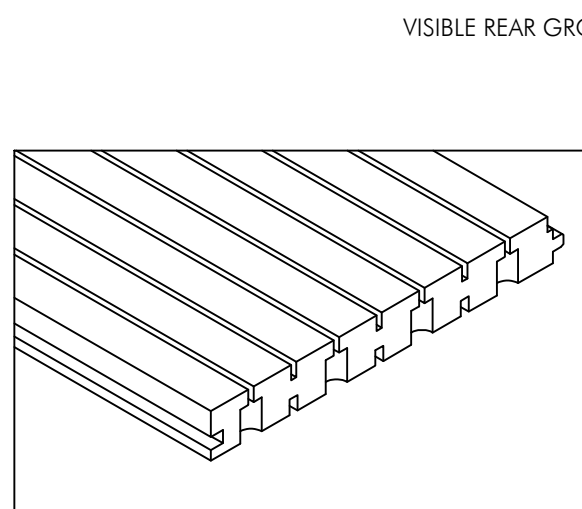
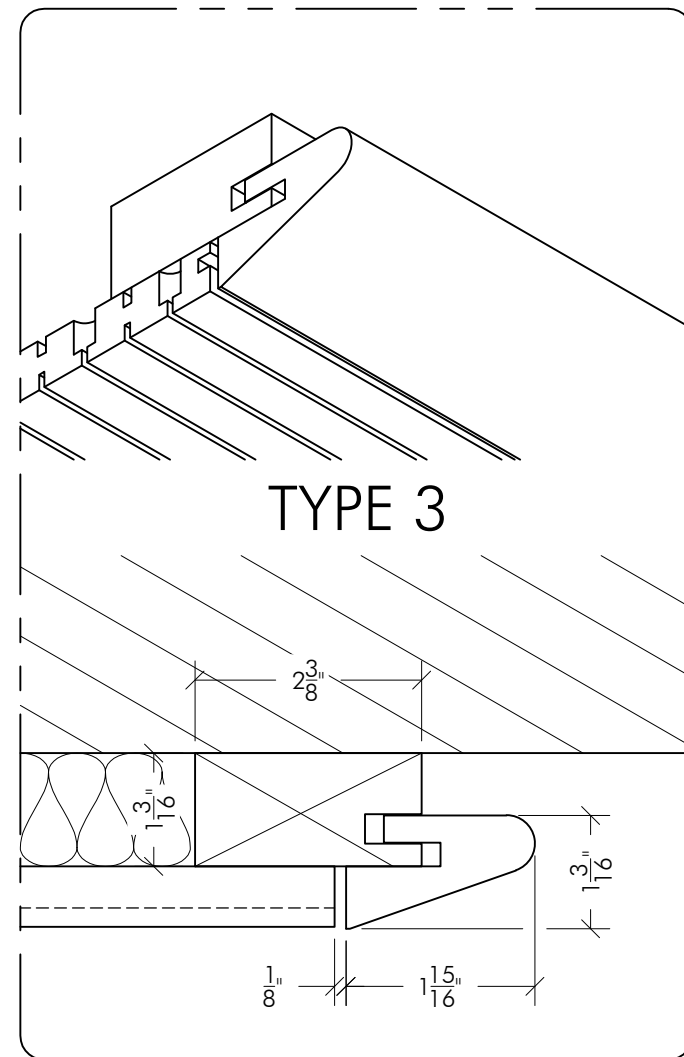
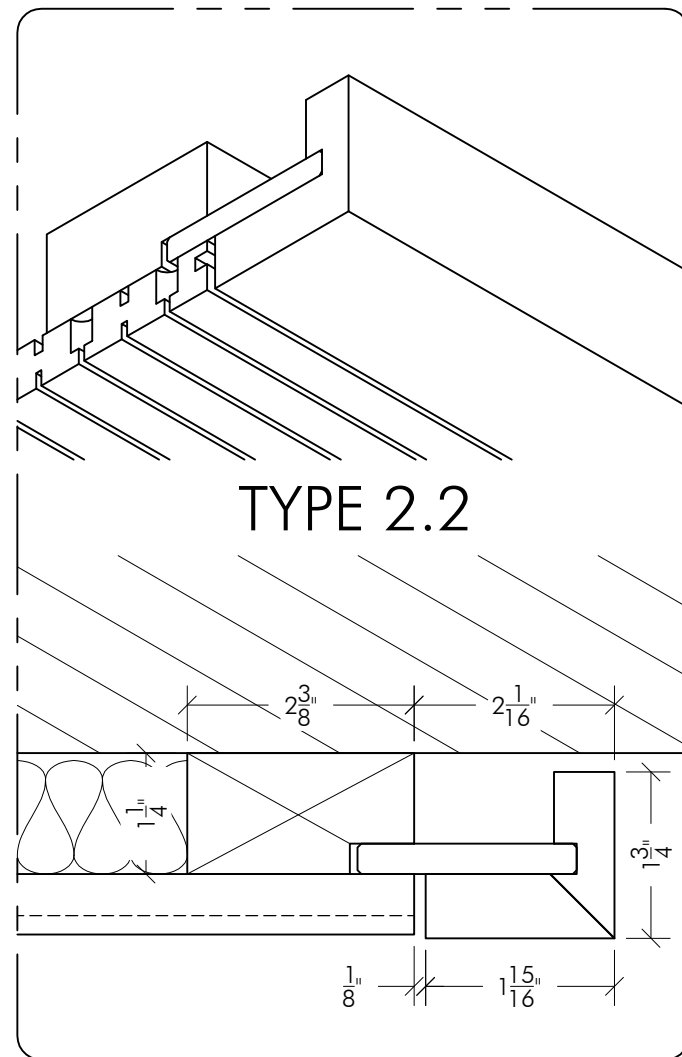
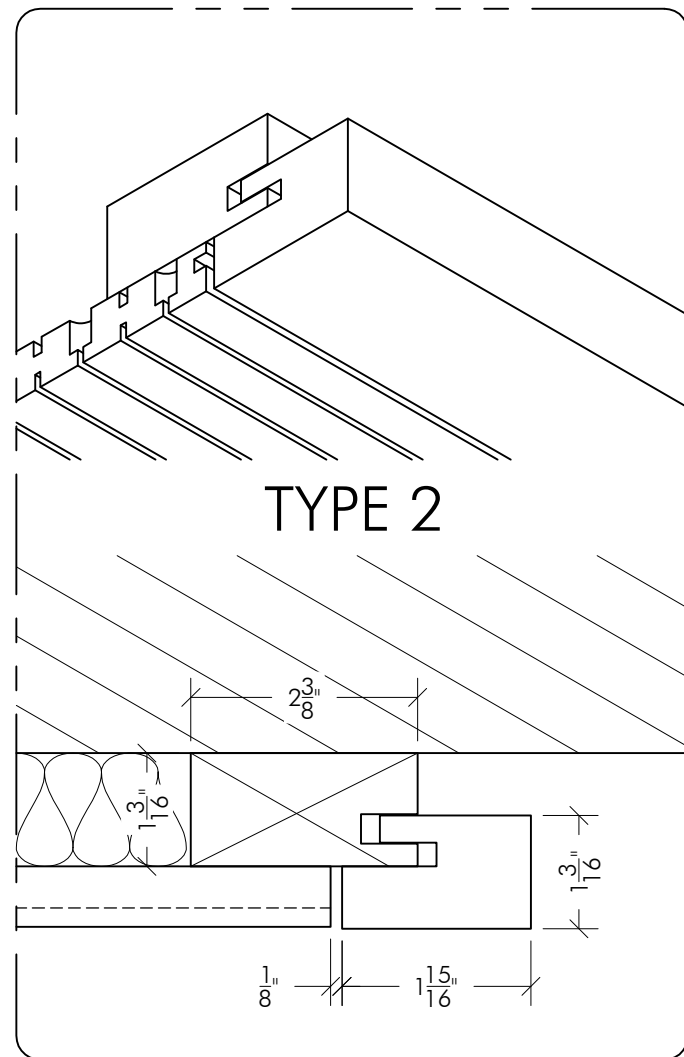
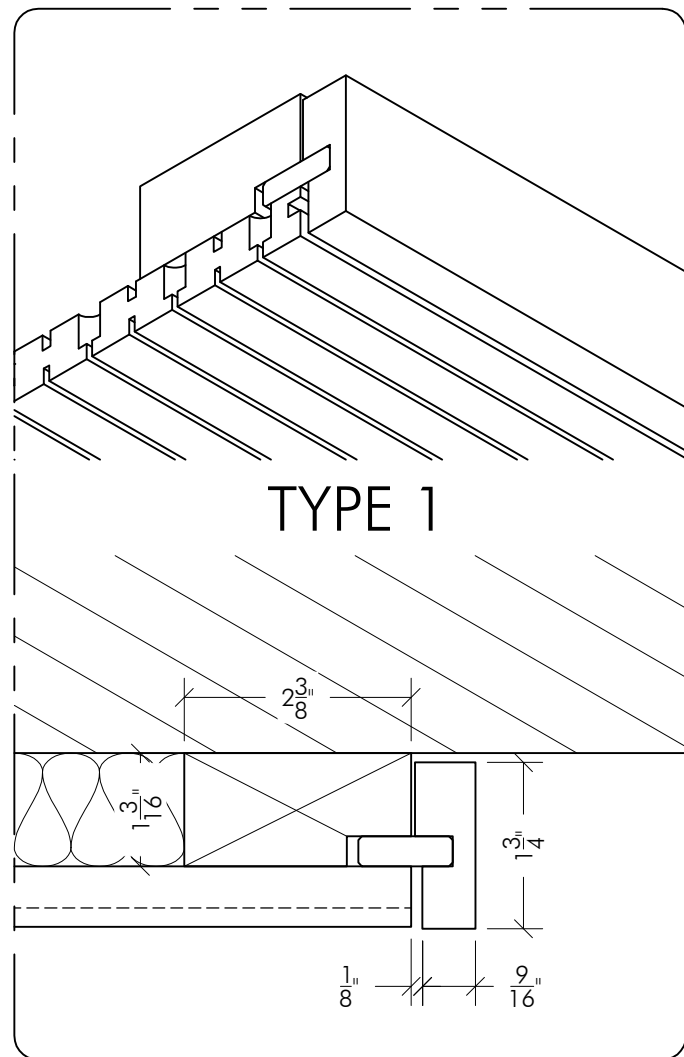

PLAIN CUT

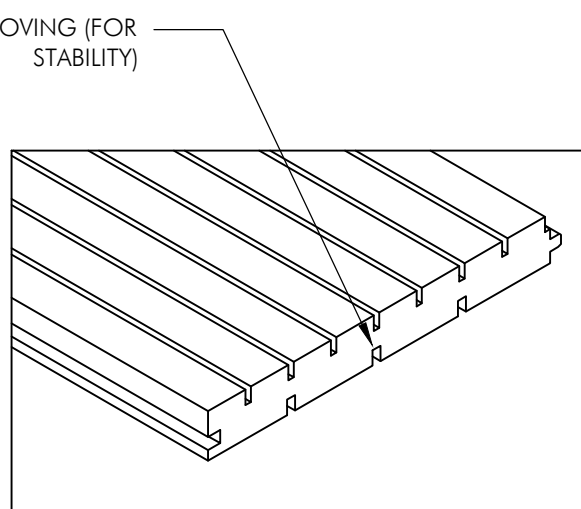

FINISHED TRANSVERSE EDGE*
REAR PERFORATIONS HELD BACK

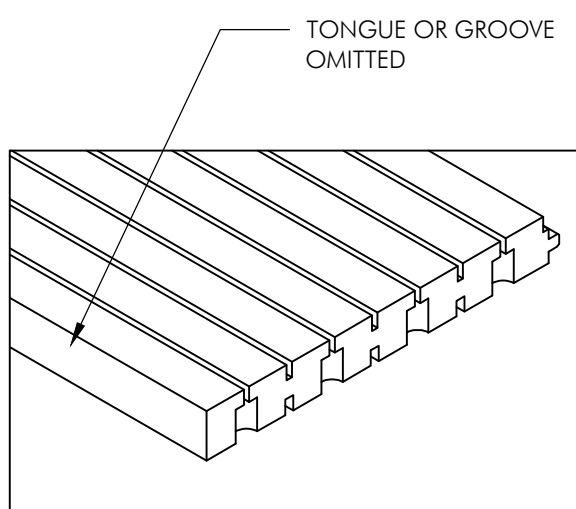

FINISHED LONGITUDINAL EDGE*

*AVAILABLE UPON REQUEST

PRODUCT: TOPAKUSTIK PLANKS		TOPAKUSTIK	
SHEET TITLE: PERIMETER OPTIONS		PRODUCTION TOLERANCE: 0" - 36" ±1/32", ±1/32" PER 36" OF PRODUCT	
SCALE: NTS	PAGE NO: 2/3	3 rd ANG. PROJ.	DRAWN BY: WRM
			REV NO: 0 REV DATE: 04/07/2015

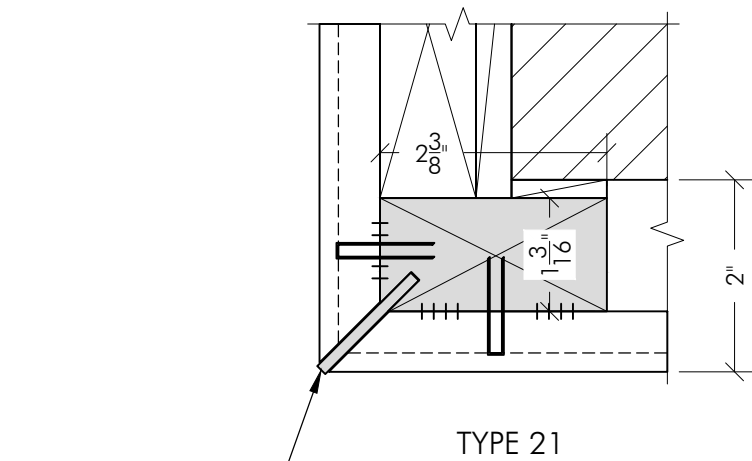

TYPE 21

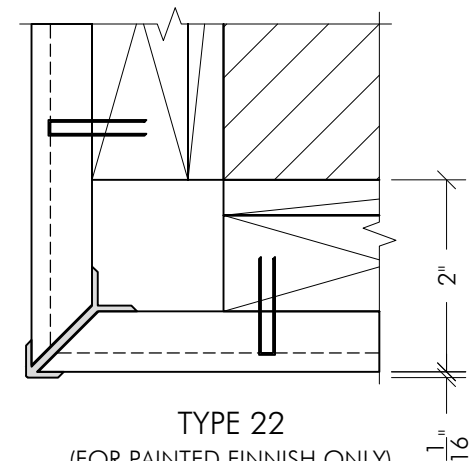

TYPE 22
(FOR PAINTED FINISH ONLY)

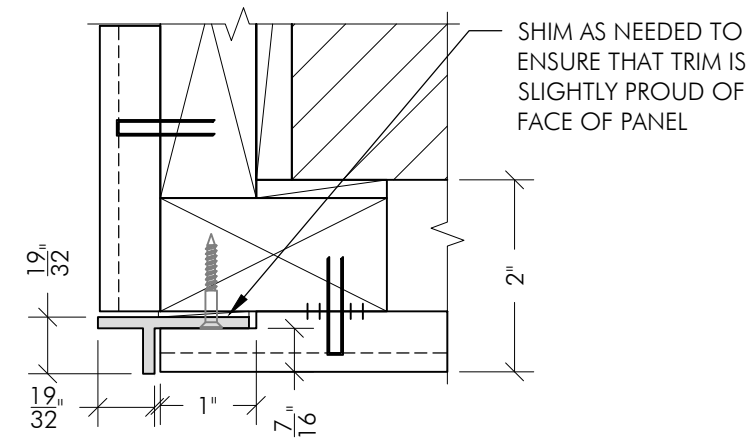

TYPE 23 CORNER

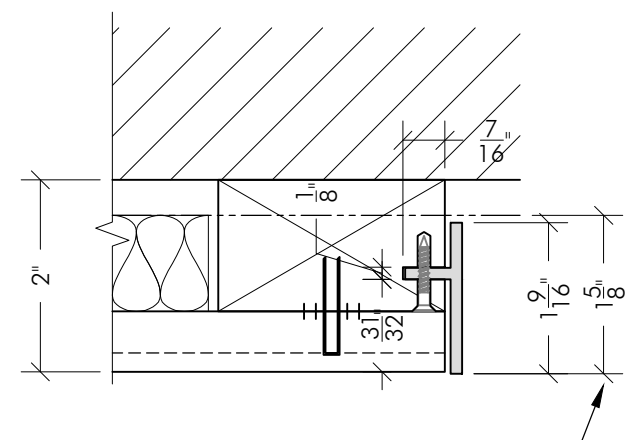

TYPE 23 END

ALUM. FLAT BAR
1/8" x 1-3/8"

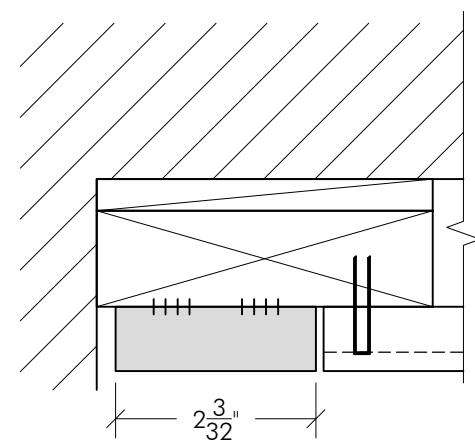
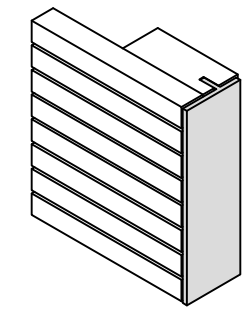
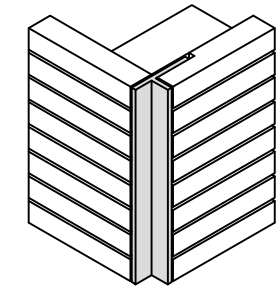
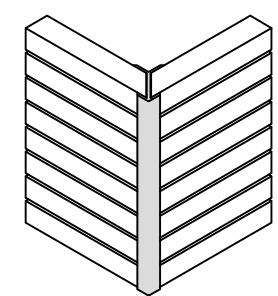
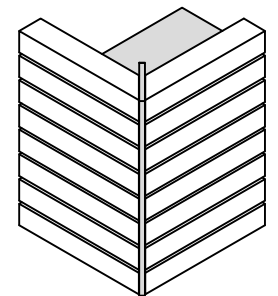

TYPE 25

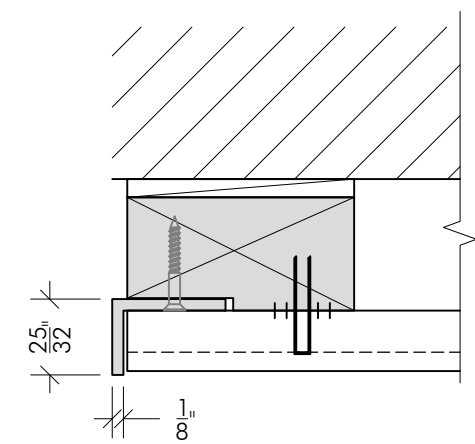
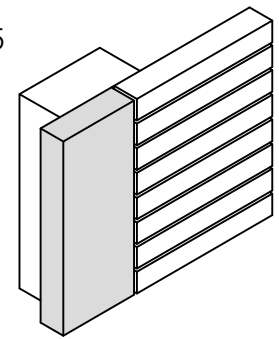

TYPE 26

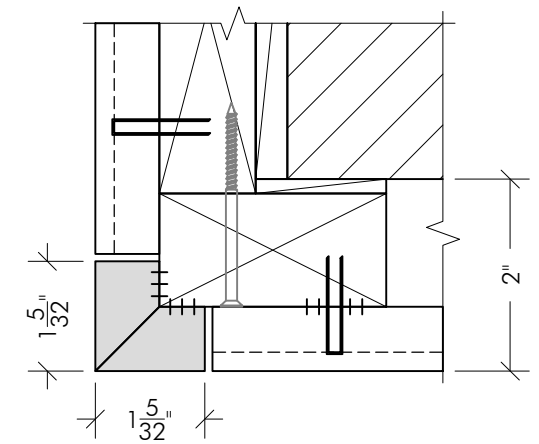
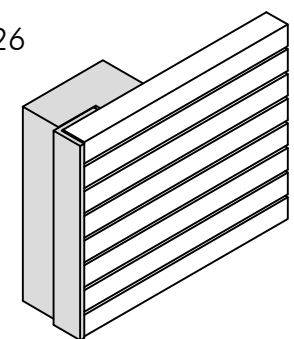

TYPE 27

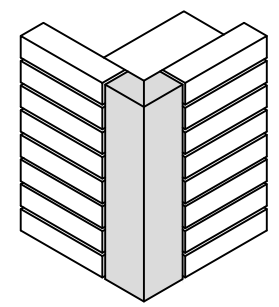

NOTE FOR PLANKS:
CUT MITERS AND RABBETS ONSITE

APPROPRIATE RECEIVING BLOCKING WILL BE PROVIDED FOR TRIMS THAT REQUIRE IT (21,24,26). BLOCKING DIMENSIONS ARE 2-3/8" x 1-3/16" (60x30mm) TYP.

PRODUCT: TOPAKUSTIK PLANKS/PANELS			TOPAKUSTIK	
SHEET TITLE: CORNER OPTIONS			PRODUCTION TOLERANCE: 0" - 36" ±1/32", ±1/32" PER 36" OF PRODUCT	
SCALE: 6"=1'-0"	PAGE NO: 3/3	3 rd ANG. PROJ.	DRAWN BY: WRM	REV NO: 0
			REV DATE: 05/18/2015	